



# IEEE Standard Definitions for the Measurement of Electric Power Quantities Under Sinusoidal, Nonsinusoidal, Balanced, or Unbalanced Conditions

---

**IEEE Power & Energy Society**

Sponsored by the  
Power System Instrumentation and Measurements Committee

1459<sup>TM</sup>

IEEE  
3 Park Avenue  
New York, NY 10016-5997, USA

19 March 2010

**IEEE Std 1459<sup>TM</sup>-2010**  
(Revision of  
IEEE Std 1459-2000)



# **IEEE Standard Definitions for the Measurement of Electric Power Quantities Under Sinusoidal, Nonsinusoidal, Balanced, or Unbalanced Conditions**

Sponsor

**Power System Instrumentation and Measurements Committee**

of the

**IEEE Power & Energy Society**

Approved 2 February 2010

**IEEE-SA Standards Board**

Figure 1 © 1983 IEEE. Reprinted, with permission, from the IEEE and R. H. Stevens.

**Abstract:** Definitions used for measurement of electric power quantities under sinusoidal, nonsinusoidal, balanced, or unbalanced conditions are provided in this standard. Mathematical expressions that were used in the past, as well as new expressions, are listed, as well as explanations of the features of the new definitions.

**Keywords:** active power, apparent power, nonactive power, power factor, reactive power, total harmonic distortion

---

The Institute of Electrical and Electronics Engineers, Inc.  
3 Park Avenue, New York, NY 10016-5997, USA

Copyright © 2010 by the Institute of Electrical and Electronics Engineers, Inc.  
All rights reserved. Published 19 March 2010. Printed in the United States of America.

IEEE is a registered trademark in the U.S. Patent & Trademark Office, owned by the Institute of Electrical and Electronics Engineers, Incorporated.

**PDF:** ISBN 978-0-7381-6058-0      STD95967  
**Print:** ISBN 978-0-7381-6059-7      STDPD95967

*IEEE prohibits discrimination, harassment and bullying. For more information, visit <http://www.ieee.org/web/aboutus/whatis/policies/p9-26.html>. No part of this publication may be reproduced in any form, in an electronic retrieval system or otherwise, without the prior written permission of the publisher.*

**IEEE Standards** documents are developed within the IEEE Societies and the Standards Coordinating Committees of the IEEE Standards Association (IEEE-SA) Standards Board. The IEEE develops its standards through a consensus development process, approved by the American National Standards Institute, which brings together volunteers representing varied viewpoints and interests to achieve the final product. Volunteers are not necessarily members of the Institute and serve without compensation. While the IEEE administers the process and establishes rules to promote fairness in the consensus development process, the IEEE does not independently evaluate, test, or verify the accuracy of any of the information or the soundness of any judgments contained in its standards.

Use of an IEEE Standard is wholly voluntary. The IEEE disclaims liability for any personal injury, property or other damage, of any nature whatsoever, whether special, indirect, consequential, or compensatory, directly or indirectly resulting from the publication, use of, or reliance upon this, or any other IEEE Standard document.

The IEEE does not warrant or represent the accuracy or content of the material contained herein, and expressly disclaims any express or implied warranty, including any implied warranty of merchantability or fitness for a specific purpose, or that the use of the material contained herein is free from patent infringement. IEEE Standards documents are supplied “**AS IS.**”

The existence of an IEEE Standard does not imply that there are no other ways to produce, test, measure, purchase, market, or provide other goods and services related to the scope of the IEEE Standard. Furthermore, the viewpoint expressed at the time a standard is approved and issued is subject to change brought about through developments in the state of the art and comments received from users of the standard. Every IEEE Standard is subjected to review at least every five years for revision or reaffirmation, or every ten years for stabilization. When a document is more than five years old and has not been reaffirmed, or more than ten years old and has not been stabilized, it is reasonable to conclude that its contents, although still of some value, do not wholly reflect the present state of the art. Users are cautioned to check to determine that they have the latest edition of any IEEE Standard.

In publishing and making this document available, the IEEE is not suggesting or rendering professional or other services for, or on behalf of, any person or entity. Nor is the IEEE undertaking to perform any duty owed by any other person or entity to another. Any person utilizing this, and any other IEEE Standards document, should rely upon his or her independent judgment in the exercise of reasonable care in any given circumstances or, as appropriate, seek the advice of a competent professional in determining the appropriateness of a given IEEE standard.

**Interpretations:** Occasionally questions may arise regarding the meaning of portions of standards as they relate to specific applications. When the need for interpretations is brought to the attention of IEEE, the Institute will initiate action to prepare appropriate responses. Since IEEE Standards represent a consensus of concerned interests, it is important to ensure that any interpretation has also received the concurrence of a balance of interests. For this reason, IEEE and the members of its societies and Standards Coordinating Committees are not able to provide an instant response to interpretation requests except in those cases where the matter has previously received formal consideration. A statement, written or oral, that is not processed in accordance with the IEEE-SA Standards Board Operations Manual shall not be considered the official position of IEEE or any of its committees and shall not be considered to be, nor be relied upon as, a formal interpretation of the IEEE. At lectures, symposia, seminars, or educational courses, an individual presenting information on IEEE standards shall make it clear that his or her views should be considered the personal views of that individual rather than the formal position, explanation, or interpretation of the IEEE.

Comments for revision of IEEE Standards are welcome from any interested party, regardless of membership affiliation with IEEE. Suggestions for changes in documents should be in the form of a proposed change of text, together with appropriate supporting comments. Recommendations to change the status of a stabilized standard should include a rationale as to why a revision or withdrawal is required. Comments and recommendations on standards, and requests for interpretations should be addressed to:

Secretary, IEEE-SA Standards Board  
445 Hoes Lane  
Piscataway, NJ 08854  
USA

Authorization to photocopy portions of any individual standard for internal or personal use is granted by The Institute of Electrical and Electronics Engineers, Inc., provided that the appropriate fee is paid to Copyright Clearance Center. To arrange for payment of licensing fee, please contact Copyright Clearance Center, Customer Service, 222 Rosewood Drive, Danvers, MA 01923 USA; +1 978 750 8400. Permission to photocopy portions of any individual standard for educational classroom use can also be obtained through the Copyright Clearance Center.

## Introduction

This introduction is not part of IEEE Std 1459-2010, IEEE Standard Definitions for the Measurement of Electric Power Quantities Under Sinusoidal, Nonsinusoidal, Balanced, or Unbalanced Conditions.

The definitions for active, reactive, and apparent powers that are currently used are based on the knowledge developed and agreed on during the 1940s. Such definitions served the industry well, as long as the current and voltage waveforms remained nearly sinusoidal.

Important changes have occurred in the last 50 years. The new environment is conditioned by the following facts:

- a) Power electronics equipment, such as Adjustable Speed Drives, Controlled Rectifiers, Cycloconverters, Electronically Ballasted Lamps, Arc and Induction Furnaces, and clusters of Personal Computers, represent major nonlinear and parametric loads proliferating among industrial and commercial customers. Such loads have the potential to create a host of disturbances for the utility and the end-user's equipment. The main problems stem from the flow of nonactive energy caused by harmonic currents and voltages.
- b) New definitions of powers have been discussed in the last 30 years in the engineering literature (Filipski and Labaj [B9]<sup>a</sup>). The mechanism of electric energy flow for nonsinusoidal and/or unbalanced conditions is well understood today.
- c) The traditional instrumentation designed for the sinusoidal 60/50 Hz waveform is prone to significant errors when the current and the voltage waveforms are distorted (Filipski and Labaj [B9]).
- d) Microprocessors and minicomputers enable today's manufacturers of electrical instruments to construct new, accurate, and versatile metering equipment that is capable of measuring electrical quantities defined by means of advanced mathematical models.
- e) There is a need to quantify correctly the distortions caused by the nonlinear and parametric loads, and to apply a fair distribution of the financial burden required to maintain the quality of electric service.

This standard lists new definitions of powers needed for the following particular situations:

- When the voltage and current waveforms are nonsinusoidal
- When the load is unbalanced or the supplying voltages are asymmetrical
- When the energy dissipated in the neutral path due to zero-sequence current components has economical significance

The new definitions were developed to give guidance with respect to the quantities that should be measured or monitored for revenue purposes, engineering economic decisions, and determination of major harmonic polluters. The following important electrical quantities are recognized by this standard:

- The power frequency (60/50 Hz or fundamental) of apparent, active, and reactive powers. These three basic quantities are the quintessence of the power flow in electric networks. They define what is generated, transmitted, distributed, and sold by the electric utilities and bought by the end users. This is the electric energy transmitted by the 60/50 Hz electromagnetic field. In poly-phase systems, the power frequency positive-sequence powers are the important dominant quantities. The power frequency positive-sequence power factor is a key value that helps determine and adjust the flow of power frequency positive-sequence reactive power. The

---

<sup>a</sup> The numbers in brackets correspond to those of the bibliography in Annex C.

fundamental positive-sequence reactive power is of utmost importance in power systems; it governs the fundamental voltage magnitude and its distribution along the feeders and affects electromechanical stability as well as the energy loss.

- The effective apparent power in three-phase systems is  $S_e = 3V_e I_e$ , where  $V_e$  and  $I_e$  are the equivalent voltage and current. In sinusoidal and balanced situations,  $S_e$  is equal to the conventional apparent power  $S = 3V_{\ell n} I = \sqrt{3}V_{\ell \ell} I$ , where  $V_{\ell n}$  and  $V_{\ell \ell}$  are the line-to-neutral and the line-to-line voltage, respectively. For sinusoidal unbalanced or for nonsinusoidal balanced or unbalanced situations,  $S_e$  allows rational and correct computation of the power factor. This quantity was proposed in 1922 by the German engineer Buchholz [B1] and in 1933 was explained by the American engineer Goodhue [B11].
- The non-60 Hz or nonfundamental apparent power is  $S_N$  (for brevity, 50 Hz power is not always mentioned). This power quantifies the overall amount of harmonic pollution delivered or absorbed by a load. It also quantifies the required capacity of dynamic compensators or active filters when used for nonfundamental compensation alone.
- Current distortion power  $D_I$  identifies the segment of nonfundamental nonactive power due to current distortion. This is usually the dominant component of  $S_N$ .
- Voltage distortion power  $D_V$  separates the nonfundamental nonactive power component due to voltage distortion.
- Apparent harmonic power  $S_H$  indicates the level of apparent power due to harmonic voltages and currents alone. This is the smallest component of  $S_N$  and includes the harmonic active power  $P_H$ .

To avoid confusion, it was decided not to add new units. The use of the watts (W) for instantaneous and active powers, volt-amperes (VA) for apparent powers, and (var) for all the nonactive powers maintains the distinct separation among these three major types of powers.

There is not yet available a generalized power theory that can provide a simultaneous common base for

- Energy billing
- Evaluation of electric energy quality
- Detection of the major sources of waveform distortion
- Theoretical calculations for the design of mitigation equipment such as active filters or dynamic compensators

This standard is meant to provide definitions extended from the well-established concepts. It is meant to serve the user who wants to measure and design instrumentation for energy and power quantification. It is not meant to help in the design of real-time control of dynamic compensators or for diagnosis instrumentation used to pinpoint to a specific type of annoying event or harmonic.

These definitions are meant to serve as a guideline and as a useful benchmark for future developments.

## Notice to users

## Laws and regulations

Users of these documents should consult all applicable laws and regulations. Compliance with the provisions of this standard does not imply compliance to any applicable regulatory requirements. Implementers of the standard are responsible for observing or referring to the applicable regulatory

requirements. IEEE does not, by the publication of its standards, intend to urge action that is not in compliance with applicable laws, and these documents may not be construed as doing so.

## Copyrights

This document is copyrighted by the IEEE. It is made available for a wide variety of both public and private uses. These include both use, by reference, in laws and regulations, and use in private self-regulation, standardization, and the promotion of engineering practices and methods. By making this document available for use and adoption by public authorities and private users, the IEEE does not waive any rights in copyright to this document.

## Updating of IEEE documents

Users of IEEE standards should be aware that these documents may be superseded at any time by the issuance of new editions or may be amended from time to time through the issuance of amendments, corrigenda, or errata. An official IEEE document at any point in time consists of the current edition of the document together with any amendments, corrigenda, or errata then in effect. In order to determine whether a given document is the current edition and whether it has been amended through the issuance of amendments, corrigenda, or errata, visit the IEEE Standards Association web site at <http://ieeexplore.ieee.org/xpl/standards.jsp>, or contact the IEEE at the address listed previously.

For more information about the IEEE Standards Association or the IEEE standards development process, visit the IEEE-SA web site at <http://standards.ieee.org>.

## Errata

Errata, if any, for this and all other standards can be accessed at the following URL: <http://standards.ieee.org/reading/ieee/updates/errata/index.html>. Users are encouraged to check this URL for errata periodically.

## Interpretations

Current interpretations can be accessed at the following URL: <http://standards.ieee.org/reading/ieee/interp/index.html>.

## Patents

Attention is called to the possibility that implementation of this standard may require use of subject matter covered by patent rights. By publication of this standard, no position is taken with respect to the existence or validity of any patent rights in connection therewith. The IEEE is not responsible for identifying Essential Patent Claims for which a license may be required, for conducting inquiries into the legal validity or scope of Patents Claims or determining whether any licensing terms or conditions provided in connection with submission of a Letter of Assurance, if any, or in any licensing agreements are reasonable or non-discriminatory. Users of this standard are expressly advised that determination of the validity of any patent rights, and the risk of infringement of such rights, is entirely their own responsibility. Further information may be obtained from the IEEE Standards Association.



## Participants

At the time this standard was submitted to the IEEE-SA Standards Board for approval, the Non-Sinusoidal Situations Working Group had the following membership:

**Alexander E. Emanuel**, *Chair*

**Eddy So**, *Sponsor*

Jose Policarpo Abreu  
Rejean Arseneau  
Santiago Barcon  
Andrew Berrisford  
Yahia Baghzouz  
Keneth B. Bowes  
James A. Braun  
Antonio Cataliotti  
David Cooper  
Valentina Cosentino  
Mikey D. Cox  
Roger H. Daugherty  
Soni Devendra  
Dario Di Cara  
William Dickerson  
Alexander Domijan

David Elmore  
Gaetan Ethier  
Erich Gunther  
Dennis Hansen  
Ernst Hanique  
Gilbert C. Hensley  
John Houdek  
Roberto Langella  
Michael Lowenstein  
William Moncrief  
Alexander McEachern  
Dalgerti Milanez  
Thomas L. Nelson  
Vuong Nguyen  
Daniel Nordell  
Salvatore Nuccio

Slobodan Pajic  
Lorenzo Peretto  
Johan H. C. Pretorius  
Paulo Ribeiro  
Daniel Sabin  
Kalyan Sen  
Piet H. Swart  
Donald Tandon  
Alfredo Testa  
Grazia Todeschini  
Daniel Ward  
Scott Weikel  
Stephan Weiss  
Douglas Williams  
Jacques L. Willems  
Daan van Wyk

The following members of the individual balloting committee voted on this standard. Balloters may have voted for approval, disapproval, or abstention.

William J. Ackerman  
Ali Al Awazi  
David Baron  
Steven Brockschink  
William Brumsickle  
Gustavo Brunello  
Yunxiang Chen  
John Cooper  
Tommy Cooper  
John Crouse  
Roger H. Daugherty  
Gary L. Donner  
Neal Dowling  
Dana Dufield  
Gearold O. H. Eidhin  
Alexander E. Emanuel  
Gary Engmann  
Paul Forquer  
Marcel Fortin  
Randall Groves  
Gary Heuston

Werner Hoelzl  
Randy Horton  
Innocent Kamwa  
Piotr Karocki  
Jon Kay  
Tanuj Khandelwal  
Yuri Khersonsky  
Harold Kirkham  
Joseph L. Koepfinger  
Jim Kulchisky  
Federico Lopez  
Michael Lowenstein  
Keith Malmedal  
Jose Marrero  
Kenneth Martin  
William McBride  
Kenneth McClenahan  
Gary Michel  
Charles Morse  
Jerry Murphy  
Bruce Muschlit

Michael S. Newman  
David Nichols  
Ulrich Pohl  
Iulian Profir  
Michael Roberts  
Charles Rogers  
Bob Saint  
Steven Sano  
Bartien Sayogo  
Thomas Schossig  
Kenneth Sedziol  
Ahmed El Serafi  
James E. Smith  
Aaron Snyder  
Eddy So  
Michael Swearingen  
David Tepen  
John Vergis  
Scott Weikel  
James Wilson  
Ahmed Zobaa

When the IEEE-SA Standards Board approved this standard on 2 February 2010, it had the following membership:

**Robert M. Grow**, *Chair*  
**Tom A. Prevost**, *Vice Chair*  
**Steve M. Mills**, *Past Chair*  
**Judith Gorman**, *Secretary*

John Barr  
Karen Bartelson  
Victor Berman  
Ted Burse  
Richard DeBlasio  
Andrew Drozd  
Mark Epstein

Alexander Gelman  
James Hughes  
Richard H. Hulett  
Young Kyun Kim  
Joseph L. Koepfing\*  
John Kulick

David J. Law  
Ted Olsen  
Glenn Parsons  
Ronald C. Petersen  
Narayanan Ramachandran  
Jon Walter Rosdahl  
Sam Sciacca

\*Member Emeritus

Also included are the following nonvoting IEEE-SA Standards Board liaisons:

Howard L. Wolfman, *TAB Representative*  
Michael Janezic, *NIST Representative*  
Satish K. Aggarwal, *NRC Representative*

Lorraine Patsco  
*IEEE Standards Program Manager, Document Development*

Matthew J. Ceglia  
*IEEE Standards Program Manager, Technical Program Development*

## Contents

1. Overview .....	1
1.1 Scope .....	1
1.2 Purpose .....	2
2. Normative references.....	2
3. Definitions .....	2
3.1 Single phase.....	2
3.2 Three-phase systems.....	13
Annex A (informative) Theoretical examples .....	30
Annex B (informative) Practical studies and measurements: A detailed explanation of apparent power components.....	34
Annex C (informative) Bibliography.....	39



# IEEE Standard Definitions for the Measurement of Electric Power Quantities Under Sinusoidal, Nonsinusoidal, Balanced, or Unbalanced Conditions

*IMPORTANT NOTICE: This standard is not intended to ensure safety, security, health, or environmental protection in all circumstances. Implementers of the standard are responsible for determining appropriate safety, security, environmental, and health practices or regulatory requirements.*

*This IEEE document is made available for use subject to important notices and legal disclaimers. These notices and disclaimers appear in all publications containing this document and may be found under the heading “Important Notice” or “Important Notices and Disclaimers Concerning IEEE Documents.” They can also be obtained on request from IEEE or viewed at <http://standards.ieee.org/IPR/disclaimers.html>*

## 1. Overview

This standard is divided into three clauses. Clause 1 lists the scope of this document. Clause 2 lists references to other standards that are useful in applying this standard. Clause 3 provides the definitions, among which there are several new expressions.

The preferred mathematical expressions recommended for the instrumentation design are marked with a || sign. The additional expressions are meant to reinforce the theoretical approach and to facilitate a better understanding of the explained concepts.

### 1.1 Scope

This document provides definitions of electric power to quantify the flow of electrical energy in single-phase and three-phase circuits under sinusoidal, nonsinusoidal, balanced, and unbalanced conditions.

## 1.2 Purpose

This document provides organizations with criteria for designing and using metering instrumentation.

## 2. Normative references

The following referenced documents are indispensable for the application of this document (i.e., they must be understood and used, so each referenced document is cited in text and its relationship to this document is explained). For dated references, only the edition cited applies. For undated references, the latest edition of the referenced document (including any amendments or corrigenda) applies.

DIN 40110-1997, Quantities Used in Alternating Current Theory.<sup>1</sup>

IEC 80000-6:2008, Quantities and Units—Part 6: Electromagnetism.<sup>2</sup>

## 3. Definitions

For the purposes of this document, the following terms and definitions apply. *The IEEE Standards Dictionary: Glossary of Terms & Definitions* should be referenced for terms not defined in this clause.<sup>3</sup>

NOTE—Mathematical expressions that are considered appropriate for instrumentation design are marked with the sign ||. When the sign || appears on the right side, it means that the last expression that is listed is favored. Each descriptor of a power type is followed by its measurement unit in parentheses.<sup>4</sup>

### 3.1 Single phase

#### 3.1.1 Single-phase sinusoidal

A sinusoidal voltage source

$$v = \sqrt{2}V \sin(\omega t)$$

supplying a linear load will produce a sinusoidal current (assumed lagging the voltage) of

$$i = \sqrt{2}I \sin(\omega t - \theta)$$

where

$V$  is the rms value of the voltage (V)  
 $I$  is the rms value of the current (A)

<sup>1</sup>DIN publications are available from DIN Deutsches Institut für Normung, e.V., Burggrafenstrabe 6, 10787 Berlin, Germany (<http://www.din.de>).

<sup>2</sup>IEC publications are available from the Sales Department of the International Electrotechnical Commission, Case Postale 131, 3 rue de Varembe, CH-1211, Genève 20, Switzerland/Suisse (<http://www.iec.ch/>). IEC publications are also available in the United States from the Sales Department, American National Standards Institute, 11 West 42nd Street, 13th Floor, New York, NY 10036, USA.

<sup>3</sup> *The IEEE Standards Dictionary: Glossary of Terms & Definitions* is available at <http://shop.ieee.org/>.

<sup>4</sup> Notes in text, tables, and figures of a standard are given for information only and do not contain requirements needed to implement this standard.

$\omega$	is the angular frequency $2\pi f$ (rad/s)
$f$	is the power system frequency (Hz)
$\theta$	is the phase angle between the current and the voltage (rad)
$t$	is the time (s)

For more information on symbols and units, see IEEE Std 280™-1985 [B13] and IEC 80000-6:2008.

### 3.1.1.1 Instantaneous power ( $W$ )

The instantaneous power  $p$  is given by

$$p = vi$$

$$p = p_a + p_q$$

where

$$p_a = VI \cos \theta [1 - \cos(2\omega t)] = P[1 - \cos(2\omega t)]; \quad P = VI \cos \theta$$

$$p_q = -VI \sin \theta \sin(2\omega t) = -Q \sin(2\omega t); \quad Q = VI \sin \theta$$

NOTE 1—The component  $p_a$  is the instantaneous active power. It is produced by the active component of the current (i.e., by the component that is in phase with the voltage). The instantaneous active power  $p_a$  is the rate of flow of the energy

$$w_a = \int_{t_0}^t p_a dt = P(t - t_0) - \frac{P}{2\omega} [\sin(2\omega t) - \sin(2\omega t_0)]$$

This energy flows unidirectional from the source to the load. Its steady-state rate of flow is not negative,  $p_a \geq 0$ .

NOTE 2—The instantaneous active power has two terms: the active or real power  $P$  and the intrinsic power  $-P \cos(2\omega t)$ . The intrinsic power is always present when net energy is transferred to the load; however, this oscillating component does not cause power loss in the supplying lines.

NOTE 3—The component  $p_q$  is the instantaneous reactive power. It is produced by the reactive component of the current (i.e., the component that is in quadrature with the voltage). The instantaneous reactive power  $p_q$  is the rate of flow of the energy

$$w_q = \int_{t_0}^t p_q dt = \frac{Q}{2\omega} [\cos(2\omega t) - \cos(2\omega t_0)]$$

This energy component oscillates between the sources and the electromagnetic energy stored within the magnetic field of the inductors and electric field of the capacitors of electrical equipment, as well as the mechanical energy stored in moving masses pertaining to electromechanical systems (motor and generator rotors, plungers, and armatures). The average value of this rate of flow is zero, and the net transfer of energy to the load is nil; nevertheless, these power oscillations do cause power loss (Joule and eddy-current) in the conductors.

### 3.1.1.2 Active power ( $W$ )

The active power  $P$ , which is also called real power, is the average value of the instantaneous power during the measurement time interval  $\tau$  to  $\tau + kT$

$$\| P = \frac{1}{kT} \int_{\tau}^{\tau+kT} p dt = \frac{1}{kT} \int_{\tau}^{\tau+kT} p_a dt$$

where

$$\begin{aligned} T &= 1/f && \text{is the cycle time (s)} \\ k &&& \text{is a positive integer number} \\ \tau &&& \text{is the moment when the measurement starts} \\ P &= VI \cos \theta \end{aligned}$$

NOTE— $P$  is also equal to the average of  $p_a$  over a period, or an integer number of periods, because the average of  $p_q$  is zero.

### 3.1.1.3 Reactive power (var)

The magnitude of the reactive power  $Q$  equals the amplitude of the oscillating instantaneous reactive power  $p_q$ .

$$Q = VI \sin \theta$$

$$Q = \frac{1}{2\pi} \oint v di = \frac{-1}{2\pi} \oint i dv = \frac{1}{kT\omega} \int_{\tau}^{\tau+kT} v \frac{di}{dt} dt = \frac{-1}{kT\omega} \int_{\tau}^{\tau+kT} i \frac{dv}{dt} dt = \frac{-\omega}{kT} \int_{\tau}^{\tau+kT} v \left[ \int i dt \right] dt$$

$$\| Q = \frac{\omega}{kT} \int_{\tau}^{\tau+kT} i \left[ \int v dt \right] dt$$

NOTE 1— If the load is inductive, then  $Q > 0$ . If the load is capacitive, then  $Q < 0$ . This means that when the current lags the voltage  $\theta > 0$  and vice versa.

NOTE 2—The application of the previous definitions to nonsinusoidal conditions is presented in A.2.

### 3.1.1.4 Apparent power (VA)

The apparent power  $S$  is the product of the root-mean-square (rms) voltage and the rms current (see *The IEEE Standards Dictionary: Glossary of Terms & Definitions*<sup>5</sup>).

$$\| S = VI$$

$$S = \sqrt{P^2 + Q^2}$$

NOTE 1—The apparent power of a single-phase load can be interpreted as the maximum active power that can be transmitted through the same line while keeping the load rms voltage  $V$  constant and the supplying line power loss constant (i.e., the rms current  $I$  constant). This is an ideal condition, for which the process of energy conversion at the load remains unchanged, but the utilization of the supplying line is improved (i.e., the thermal stress of the line or cable remains the same while the amount of energy transmitted through the supplying line is increased). This concept implies that an additional load with unity power factor can be connected in parallel with the original load compensated by means of a shunt capacitance or an active compensator.

NOTE 2—The instantaneous power  $p$  follows a sinusoidal oscillation with a frequency  $2f = 2\omega / 2\pi$  biased by the active power  $P$ . The amplitude of the sinusoidal oscillation is the apparent power  $S$ .

<sup>5</sup> The *IEEE Standards Dictionary: Glossary of Terms & Definitions* is available at <http://shop.ieee.org/>.



### 3.1.1.5 Power factor

$$\text{PF} = \frac{P}{S}$$

NOTE 1—The power factor can be interpreted as the ratio between the energy transmitted to the load over the maximum energy that could be transmitted provided the line losses are kept the same.

NOTE 2—For a given  $S$  and  $V$ , maximum utilization of the line is obtained when  $P = S$ ; hence, the ratio  $P/S$  is a utilization factor indicator.

NOTE 3—When a load, or a cluster of loads, is to be compensated to a higher power factor, the load voltage will increase by a certain increment. If the new voltage is larger than the recommended value, the load voltage can be reduced and brought within recommended range by means of voltage regulators, transformer tap-changers, or other methods of voltage control.

### 3.1.1.6 Complex power (VA)

The complex power is a complex quantity in which the active power is the real part and the reactive power is the imaginary part

$$S = P + jQ = \mathbf{V} \mathbf{I}^*$$

where according to 3.1.1

$$\mathbf{V} = V \angle 0^\circ \quad \text{is the voltage phasor}$$

$$\mathbf{I} = I \angle -\theta \quad \text{is the current phasor}$$

$$\mathbf{I}^* = I \angle \theta \quad \text{is the complex conjugate of the current phasor}$$

This expression stems from the power triangle,  $S$ ,  $P$ , and  $Q$ , and is useful in power flow studies. Figure 1 summarizes the conventional power flow directions as interpreted in literature (see Stevens [B19]). The angle  $\theta$  is the phase angle of the equivalent complex impedance  $Z \angle \theta = \mathbf{V} / \mathbf{I}$ .

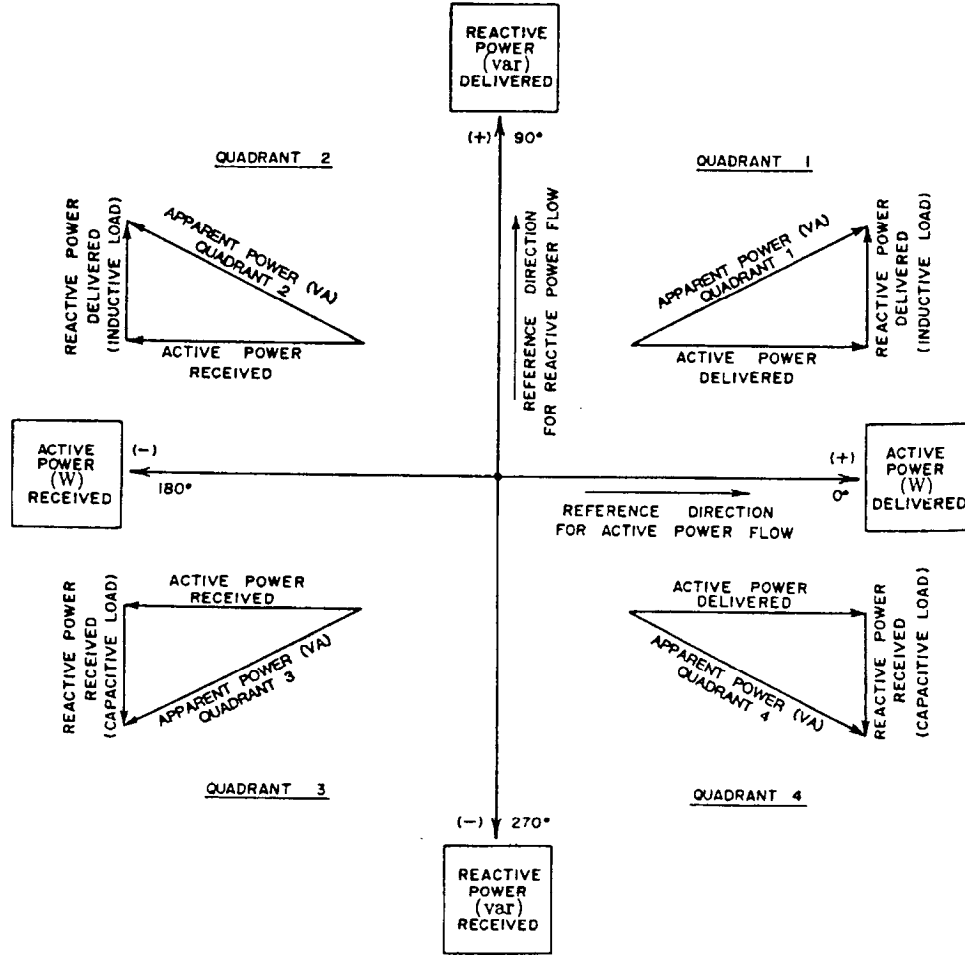

Figure 1—Four-quadrant power flow directions  
 (© 1983 IEEE. Reprinted, with permission, from the IEEE and R. H. Stevens [B19])

### 3.1.2 Single-phase nonsinusoidal

For steady-state conditions, a nonsinusoidal periodical instantaneous voltage or current has two distinct components: the power system frequency components  $v_1$  and  $i_1$  and the remaining term  $v_H$  and  $i_H$ , respectively.

$$v = v_1 + v_H \text{ and } i = i_1 + i_H$$

where

$$v_1 = \sqrt{2}V_1 \sin(\omega t - \alpha_1)$$

$$i_1 = \sqrt{2}I_1 \sin(\omega t - \beta_1)$$

$$v_H = V_0 + \sqrt{2} \sum_{h \neq 1} V_h \sin(h\omega t - \alpha_h)$$

$$i_H = I_0 + \sqrt{2} \sum_{h \neq 1} I_h \sin(h\omega t - \beta_h)$$

The corresponding rms values squared are as follows:

$$V^2 = \frac{1}{kT} \int_{\tau}^{\tau+kT} v^2 dt = V_1^2 + V_H^2$$

$$I^2 = \frac{1}{kT} \int_{\tau}^{\tau+kT} i^2 dt = I_1^2 + I_H^2$$

where

$$V_H^2 = V_0^2 + \sum_{h \neq 1} V_h^2 = V^2 - V_1^2 \quad ||$$

and

$$I_H^2 = I_0^2 + \sum_{h \neq 1} I_h^2 = I^2 - I_1^2 \quad ||$$

are the squares of the rms values of  $v_H$  and  $i_H$ , respectively.

NOTE 1—The direct voltage and the direct current terms  $V_0$  and  $I_0$ , must be included in  $V_H$  and  $I_H$ . Significant direct current (dc) components are rarely present in alternating current (ac) power systems; however, traces of dc are common.

NOTE 2—Distorted waveforms often contain frequency components called interharmonics (see IEC 61000-4-7:2002 [B12]). A special group of interharmonics is characterized by  $h < 1$ . The components belonging to this group have periods larger than the period  $T$  of the fundamental frequency. They are called subsynchronous frequency components or subsynchronous interharmonics (in the earlier documents, they are called subharmonics).

NOTE 3—If the distorted voltage and current waveforms consist of harmonics only, then a measurement time interval  $kT$  (see 3.1.1.2) enables the correct measurement of rms and power values. If the monitored waveform contains an interharmonic, the measurement time interval  $kT$ , which is needed to correctly measure rms values and powers, is the least common multiple of the periods of the fundamental component and the interharmonic component (i.e.,  $kT = mT_i$ ;  $T_i = 1/f_i$ , where  $f_i$  is the interharmonic frequency and  $k, m =$  integer numbers). When the measurement time interval  $kT$  does not include an integer number of periods  $T_i$  (i.e.,  $kT \neq mT_i$ ), the rms value of the interharmonic as well as the powers associated with it are incorrectly measured (see Peretto et al. [B17]). This error is also reflected in the measurement accuracy of the total rms and powers values. The error is also compounded by the fact that cross-products between the interharmonic current and harmonic voltages (and vice versa) do not yield instantaneous powers with zero mean value.

If at least one of the interharmonics of order  $h$  is an irrational number, then the observed waveform is not periodic (it is called nearly periodic.) In such a case, the measurement time interval  $kT$  should be infinitely large to have a correct measurement of the rms value or power. For practical situations when the bulk power is carried by the fundamental components, such errors are small (see A.1). The larger the measurement time  $kT$ , the less significant become the errors caused by interharmonics (see Peretto et al. [B16]). The theoretical measurement error created when the active power of an interharmonic is measured is strongly affected by the phase angle between the voltage and the current. The closer the phase angle is to  $\pm 90^\circ$ , the larger becomes the error (see Peretto et al. [B16]).

Figure 2 presents the envelopes of the maximum errors made when the rms value of an interharmonic is measured in function of the number of cycles  $m$ .

For example, if  $m = 20$ , the rms value of the interharmonic will be measured with a maximum error of  $\pm 0.2\%$ .

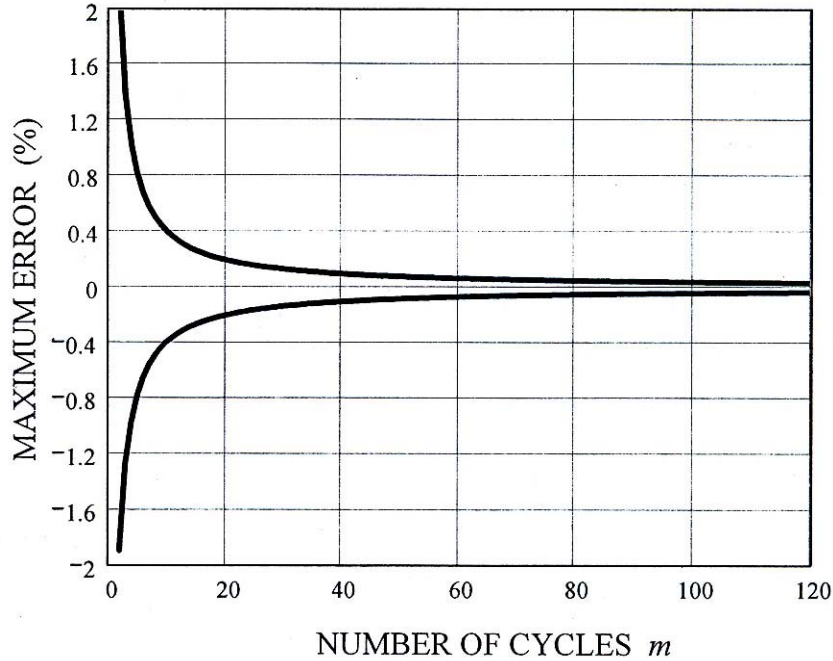

**Figure 2—Percent maximum error of rms measurement versus number of cycles**

### 3.1.2.1 Total harmonic distortion (THD)

The overall deviation of a distorted wave from its fundamental can be estimated with the help of the total harmonic distortion. The total harmonic distortion of the voltage is as follows:

$$\| \text{THD}_V = \frac{V_H}{V_1} = \sqrt{\left(\frac{V}{V_1}\right)^2 - 1}$$

The total harmonic distortion of the current is as follows:

$$\| \text{THD}_I = \frac{I_H}{I_1} = \sqrt{\left(\frac{I}{I_1}\right)^2 - 1}$$

### 3.1.2.2 Instantaneous power (W)

$$p = vi$$

$$P = P_a + P_q$$

where the first term

$$P_a = V_0 I_0 + \sum_h V_h I_h \cos \theta_h [1 - \cos(2h\omega t - 2\alpha_h)]$$

is the part of the instantaneous power that is equal to the sum of harmonic active powers. The harmonic active power of order  $h$  is caused by the harmonic voltage of order  $h$  and the component of the harmonic current of order  $h$  in-phase with the harmonic voltage of order  $h$ . Each instantaneous active power of order  $h$  has two terms: an active, or real, harmonic power  $P_h = V_h I_h \cos \theta_h$ , and the intrinsic harmonic power  $-P_h \cos(2h\omega t - 2\alpha_h)$ , which does not contribute to net transfer of energy or to additional power loss in conductors.

The second term  $p_q$  is a term that does not represent a net transfer of energy (i.e., its average value is nil); nevertheless, the current related to these nonactive components causes additional power loss in conductors.

$$p_q = -\sum_h V_h I_h \sin \theta_h \sin(2h\omega t - 2\alpha_h) + 2 \sum_n \sum_{\substack{m \\ m \neq n}} V_m I_n \sin(m\omega t - \alpha_m) \sin(n\omega t - \beta_n) \\ + \sqrt{2} V_0 \sum_h I_h \sin(h\omega t - \beta_h) + \sqrt{2} I_0 \sum_h V_h \sin(h\omega t - \alpha_h)$$

The angle  $\theta_h = \beta_h - \alpha_h$  is the phase angle between the phasors  $V_h$  and  $I_h$ .

### 3.1.2.3 Active power (W)

$$\| P = \frac{1}{kT} \int_{\tau}^{\tau+kT} p dt = \frac{1}{kT} \int_{\tau}^{\tau+kT} p_a dt$$

$$P = P_1 + P_H$$

The components  $P_1$  and  $P_H$  are defined in 3.1.2.4 and 3.1.2.5.

### 3.1.2.4 Fundamental active power (W)

$$\| P_1 = \frac{1}{kT} \int_{\tau}^{\tau+kT} v_1 i_1 dt = V_1 I_1 \cos \theta_1$$

NOTE—The fundamental active power is often referred to by the fundamental frequency. For example, for a 60 Hz power system  $P_1$  can be referred to as “60 Hz active power.”

### 3.1.2.5 Harmonic active power (nonfundamental active power) (W)

$$P_H = V_0 I_0 + \sum_{h \neq 1} V_h I_h \cos \theta_h = P - P_1 \|$$

NOTE 1— $P_H$  as defined contains also components for which  $h$  is not an integer (i.e., interharmonics and subharmonics).

NOTE 2—For ac motors, which make up most loads, the harmonic active power is not a useful power (does not contribute to the positive sequence torque). Consequently, it is meaningful to separate the fundamental active power  $P_1$  from the harmonic active power  $P_H$ .

NOTE 3—When it is necessary to compute separately the powers of a component with a noninteger value of  $h$ , caution must be used. A measurement error will be caused if the measurement time interval  $kT$  is not an integer number of periods  $T/h$  ( $T/h$  being the period of the observed component).

NOTE 4—The harmonic active power is often referred to by the fundamental frequency. For example, for a 60 Hz power system,  $P_H$  can be referred to as “non-60 Hz active power.”

### 3.1.2.6 Fundamental reactive power (var)

$$\begin{aligned} \|Q_1 &= \frac{\omega}{kT} \int_{\tau}^{\tau+kT} i_1 \left[ \int v_1 dt \right] dt \\ &= V_1 I_1 \sin \theta_1 \end{aligned}$$

### 3.1.2.7 Apparent power (VA)

$$\|S = VI$$

NOTE 1—Apparent power is the amount of active power that can be supplied to a load, or a cluster of loads, under ideal conditions. The ideal conditions may assume the load supplied with sinusoidal voltage and current. The loads are compensated by means of active or passive devices such that the line current is sinusoidal and in phase with the voltage that, ideally, is also adjusted to be sinusoidal. The rms value of the current  $I$  is kept equal with the line rms value of the actual current. The load voltage is adjusted to a value that yields unchanged load performance (i.e., the same amount of useful energy is converted and delivered by the load). If the performance criterion is the electrothermal conversion of the electric energy, then the rms value of the voltage at the terminals where the measurement is implemented must be kept constant.

NOTE 2—An important practical property of  $S$  is that the power loss  $\Delta P$ , in the feeder that supplies the apparent power  $S$ , is a nearly linear function of  $S^2$  (see Emanuel [B7]).

$$\Delta P = \frac{r_e}{V^2} S^2 + \frac{V^2}{R}$$

where

- $R$  is an equivalent shunt resistance, representing transformer core losses and cable dielectric losses
- $r_e$  is the effective Thevenin resistance. Theoretically  $r_e$  can be obtained from the equivalence of losses as follows:

$$r_e I^2 = r_{dc} \sum_h K_{sh} I_h^2$$

where

$$I = S / V$$

- $K_{sh} > 1$  is a coefficient that accounts for the skin effect and proximity effect, as well as the losses caused in cable sheath. This coefficient is a function of harmonic frequency and the geometry and conductors' material. The value of  $r_e$  is affected by the current harmonic spectrum.

- $r_{dc}$  is the Thevenin dc resistance ( $\Omega$ ).

### 3.1.2.8 Fundamental apparent power (VA)

Fundamental apparent power  $S_1$  and its components  $P_1$  and  $Q_1$  are the actual quantities that help define the rate of flow of the electromagnetic field energy associated with the fundamental voltage and current

$$\| S_1 = V_1 I_1$$

$$S_1^2 = P_1^2 + Q_1^2$$

NOTE—The fundamental apparent power is often referred to by the fundamental frequency. For example, for a 60 Hz power system,  $S_1$  can be referred to as “60 Hz apparent power.”

### 3.1.2.9 Nonfundamental apparent power (VA)

The separation of the rms current and voltage into fundamental and harmonic terms (see 3.1.2) resolves the apparent power in the following manner (see Emanuel [B8]):

$$S^2 = (VI)^2 = (V_1^2 + V_H^2)(I_1^2 + I_H^2) = (V_1 I_1)^2 + (V_1 I_H)^2 + (V_H I_1)^2 + (V_H I_H)^2 = S_1^2 + S_N^2$$

$$\| S_N = \sqrt{S^2 - S_1^2}$$

is the nonfundamental apparent power and is resolved in the following three distinctive terms:

$$S_N^2 = D_I^2 + D_V^2 + S_H^2$$

### 3.1.2.10 Current distortion power (var)

$$D_I = V_1 I_H = S_1 (\text{THD}_I) \parallel$$

### 3.1.2.11 Voltage distortion power (var)

$$D_V = V_H I_1 = S_1 (\text{THD}_V) \parallel$$

### 3.1.2.12 Harmonic apparent power (VA)

$$S_H = V_H I_H = S_1 (\text{THD}_I) (\text{THD}_V) \parallel$$

$$S_H = \sqrt{P_H^2 + D_H^2}$$

### 3.1.2.13 Harmonic distortion power (var)

$$\| D_H = \sqrt{S_H^2 - P_H^2}$$

In practical power systems,  $\text{THD}_V < \text{THD}_I$ , and  $S_N$  can be computed using the following expression (see Emanuel [B8]):

$$S_N \approx S_1 \sqrt{(\text{THD}_I)^2 + (\text{THD}_V)^2}$$

When  $\text{THD}_V \leq 5\%$ , this expression yields an error less than 0.15% for any value of  $\text{THD}_I$ .

For  $\text{THD}_V < 5\%$  and  $\text{THD}_I > 40\%$ , an error less than 1.00% is obtained using the following expression (see Emanuel [B8]):

$$S_N \approx S_1 (\text{THD}_I)$$

### 3.1.2.14 Nonactive power (var)

$$\| N = \sqrt{S^2 - P^2}$$

This power lumps together both fundamental and nonfundamental nonactive components. In the past, this power was called “fictitious power.” The nonactive power  $N$  shall not be confused with a reactive power. Only when the waveforms are perfectly sinusoidal,  $N = Q_1 = Q$ .

### 3.1.2.15 Fundamental power factor

$$\text{PF}_1 = \cos \theta_1 = \frac{P_1}{S_1} \parallel$$

This ratio helps evaluate separately the fundamental power flow conditions. It can be called the fundamental power factor. The fundamental power factor is often referred to by the fundamental frequency. For example, for a 60 Hz power system  $\text{PF}_1$  can be referred to as 60 Hz power factor.  $\text{PF}_1$  is also often referred to as the displacement power factor.

### 3.1.2.16 Power factor

$$\parallel \text{PF} = \frac{P}{S}$$

$$\text{PF} = \frac{P}{S} = \frac{P_1 + P_H}{\sqrt{S_1^2 + S_N^2}} = \frac{(P_1 / S_1)[1 + (P_H / P_1)]}{\sqrt{1 + (S_N / S_1)^2}} = \frac{[1 + (P_H / P_1)]\text{PF}_1}{\sqrt{1 + \text{THD}_I^2 + \text{THD}_V^2 + (\text{THD}_I \text{THD}_V)^2}}$$

NOTE 1—For a given  $S$  and  $V$ , maximum utilization of the line is obtained when  $P = S$ ; hence, the ratio  $P/S$  is a utilization factor indicator.

NOTE 2—The overall degree of harmonic injection produced by a large nonlinear load, or by a group of loads or consumers, can be estimated from the ratio  $S_N/S_I$ . The effectiveness of harmonic filters also can be evaluated from such a measurement. The measurements of  $S_I$ ,  $P_I$ ,  $\text{PF}_1$ , or  $Q_I$  help establish the characteristics of the fundamental power flow.



NOTE 3—In most common practical situations, it is difficult to measure correctly the higher order components of  $P_H$  using simple instrumentation. The main reason for this difficulty stems from the fact that the phase angle between the voltage phasor  $V_h$  and the current phasor  $I_h$  may be near  $\pm\pi/2$ , so even small errors in phase angle measurement can cause large errors in  $P_H$ , even to the extent of changing the sign of  $P_H$ . Thus, one should use instrumentation optimized specifically for measurements of  $P_H$  components when making technical decisions regarding harmonics compensation, energy tariffs, or the quantification of the detrimental effects made by a nonlinear or parametric load to a particular power system (see Emanuel [B8], IEEE Working Group on Non-sinusoidal Situations [B14], and Swart et al. [B20]).

NOTE 4—When  $\text{THD}_V < 5\%$  and  $\text{THD}_I > 40\%$ , it is convenient to use the following expression:

$$\text{PF} \approx \frac{1}{\sqrt{1 + \text{THD}_I^2}} \text{PF}_1$$

NOTE 5— In typical nonsinusoidal situations,  $D_I > D_V > S_H > P_H$ .

The definitions presented in 3.1.2.8 through 3.1.2.16 are summarized in Table 1.

**Table 1—Summary and grouping of the quantities in single-phase systems with nonsinusoidal waveforms**

Quantity or indicator	Combined	Fundamental powers	Nonfundamental powers
Apparent	$S$ (VA)	$S_1$ (VA)	$S_N$ $S_H$ (VA)
Active	$P$ (W)	$P_1$ (W)	$P_H$ (W)
Nonactive	$N$ (var)	$Q_1$ (var)	$D_I$ $D_V$ $D_H$ (var)
Line utilization	$\text{PF} = P/S$	$\text{PF}_1 = P_1/S_1$	—
Harmonic pollution	—	—	$S_N/S_1$

NOTE—A more detailed explanation of the power components followed by a numerical example is presented in Annex B.

## 3.2 Three-phase systems

### 3.2.1 Three-phase sinusoidal balanced

In this case assuming a counterclockwise rotating positive-sequence system,  $a$ ,  $b$ ,  $c$ , the line-to-neutral voltages are as follows:

$$v_a = \sqrt{2} V \sin(\omega t)$$

$$v_b = \sqrt{2} V \sin(\omega t - 120^\circ)$$

$$v_c = \sqrt{2} V \sin(\omega t + 120^\circ)$$

The line currents have similar expressions, and they are as follows:

$$i_a = \sqrt{2} I \sin(\omega t - \theta)$$

$$i_b = \sqrt{2} I \sin(\omega t - \theta - 120^\circ)$$

$$i_c = \sqrt{2} I \sin(\omega t - \theta + 120^\circ)$$

NOTE 1—Perfectly sinusoidal and balanced three-phase, low-voltage systems are uncommon. Only under laboratory conditions, using low-distortion power amplifiers, is it possible to work with ac power sources with  $\text{THD}_V < 0.1\%$  and voltage unbalance  $V^-/V^+ < 0.1\%$ . Practical low-voltage systems will rarely operate with  $\text{THD}_V < 1\%$  and  $V^-/V^+ < 0.4\%$ , where  $V^+$  and  $V^-$  are the positive- and negative-sequence voltages.

NOTE 2—In the case of three-wire systems, the line-to-neutral voltages are defined assuming an artificial neutral node, which can be obtained with the help of three identical resistances connected in Y.

### 3.2.1.1 Instantaneous power (W)

For three-wire systems  $i_a + i_b + i_c = 0$ , and the instantaneous power has the following expressions:

$$\| p = v_{ab}i_a + v_{cb}i_c = v_{ac}i_a + v_{bc}i_b = v_{ba}i_b + v_{ca}i_c = P$$

where  $v_{ab}$ ,  $v_{bc}$ , and  $v_{ca}$  are instantaneous line-to-line voltages. Because the voltages and the currents are balanced, the instantaneous power  $p$  is constant and equal to the active power  $P$ .

For four-wire systems

$$\| p = v_a i_a + v_b i_b + v_c i_c = P$$

If the voltages are referred to an arbitrary reference point  $r$ , then the expression of the instantaneous power is as follows:

$$\| p = v_{ar}i_a + v_{br}i_b + v_{cr}i_c = P$$

where  $v_{ar}$ ,  $v_{br}$ , and  $v_{cr}$  are instantaneous line-to-reference point voltages.

### 3.2.1.2 Active power (W)

$$\| P = \frac{1}{kT} \int_{\tau}^{\tau+kT} p dt$$

$$P = 3VI \cos \theta = \sqrt{3} V_{\ell\ell} I \cos \theta$$

where

$V$  is line-to neutral rms voltage

$V_{\ell\ell}$  is line-to-line rms voltage

### 3.2.1.3 Reactive power (var)

$$Q = 3VI \sin \theta = \sqrt{3} V_{\ell\ell} I \sin \theta$$

$$\| |Q| = \sqrt{S^2 - P^2}$$

where  $S$  is defined in 3.2.1.4.

### 3.2.1.4 Apparent power (VA)

$$\| S = 3VI = \sqrt{3} V_{\ell\ell} I$$

### 3.2.1.5 Power factor

$$\| \text{PF} = \frac{P}{S}$$

## 3.2.2 Three-phase sinusoidal unbalanced

In this case, the three current phasors  $I_a$ ,  $I_b$ , and  $I_c$ , do not have equal magnitudes, and they are not shifted exactly  $120^\circ$  with respect to each other. Load imbalance leads to asymmetrical currents that in turn cause voltage asymmetry. There are situations when the three voltage phasors are not symmetrical. This leads to asymmetrical currents even when the load is perfectly balanced.

The line-to-neutral voltages are as follows:

$$v_a = \sqrt{2} V_a \sin(\omega t + \alpha_a)$$

$$v_b = \sqrt{2} V_b \sin(\omega t + \alpha_b - 120^\circ)$$

$$v_c = \sqrt{2} V_c \sin(\omega t + \alpha_c + 120^\circ)$$

where at least one of the three line-to-neutral amplitudes  $\sqrt{2}V_a$ ,  $\sqrt{2}V_b$ , or  $\sqrt{2}V_c$  has a value different than the value of the other two amplitudes. The same may apply to the phase angles  $\alpha_a$ ,  $\alpha_b$ , and  $\alpha_c$ . If one phase angle has a value different than the value of the other two, the system is losing its symmetry and is unbalanced.

The line currents have similar expressions. They are as follows:

$$i_a = \sqrt{2} I_a \sin(\omega t + \beta_a)$$

$$i_b = \sqrt{2} I_b \sin(\omega t + \beta_b - 120^\circ)$$

$$i_c = \sqrt{2} I_c \sin(\omega t + \beta_c - 120^\circ)$$

NOTE—In the case of three-wire systems, the line-to-neutral voltages are defined assuming an artificial neutral node, which can be obtained with the help of three identical resistances connected in Y.

### 3.2.2.1 Instantaneous power (W)

For three-wire systems,  $i_a + i_b + i_c = 0$ , and the instantaneous power has the following expressions:

$$\| p = v_{ab}i_a + v_{cb}i_c = v_{ba}i_b + v_{ca}i_c = v_{ac}i_a + v_{bc}i_b$$

where  $v_{ab}$ ,  $v_{bc}$ , and  $v_{ca}$  are instantaneous line-to-line voltages.

For four-wire systems,

$$\| p = v_a i_a + v_b i_b + v_c i_c$$

If the voltages are referred to an arbitrary reference point  $r$ , then the expression of the instantaneous power is as follows:

$$\| p = v_{ar}i_a + v_{br}i_b + v_{cr}i_c$$

where  $v_{ar}$ ,  $v_{br}$ , and  $v_{cr}$  are instantaneous line-to-reference point voltages.

### 3.2.2.2 Active power (W)

$$\| P = \frac{1}{kT} \int_{\tau}^{\tau+kT} p dt$$

$$\| P = P_a + P_b + P_c$$

where  $P_a$ ,  $P_b$ , and  $P_c$  are phase active powers:

$$\| P_a = \frac{1}{kT} \int_{\tau}^{\tau+kT} v_a i_a dt = V_a I_a \cos \theta_a ; \quad \theta_a = \alpha_a - \beta_a$$

$$\| P_b = \frac{1}{kT} \int_{\tau}^{\tau+kT} v_b i_b dt = V_b I_b \cos \theta_b ; \quad \theta_b = \alpha_b - \beta_b$$

$$\| P_c = \frac{1}{kT} \int_{\tau}^{\tau+kT} v_c i_c dt = V_c I_c \cos \theta_c ; \quad \theta_c = \alpha_c - \beta_c$$

#### 3.2.2.2.1 Positive-, negative-, and zero-sequence active powers (W)

In systems with four-wires there are situations when the use of symmetrical components may be helpful. The symmetrical voltage components  $V^+$ ,  $V^-$ , and  $V^0$  and current components  $I^+$ ,  $I^-$ , and  $I^0$  with the respective phase angles  $\theta^+$ ,  $\theta^-$ , and  $\theta^0$  yield the following three active power components:

The positive-sequence active power

$$P^+ = 3V^+ I^+ \cos \theta^+$$

The negative-sequence active power

$$P^- = 3V^- I^- \cos \theta^-$$

The zero-sequence active power

$$P^0 = 3V^0 I^0 \cos \theta^0$$

The total active power is

$$P = P^+ + P^- + P^0$$

### 3.2.2.3 Reactive power (var)

Per-phase reactive powers are defined with the help of the following expressions:

$$Q_a = \frac{\omega}{kT} \int_{\tau}^{\tau+kT} i_a \left[ \int v_a dt \right] dt = V_a I_a \sin \theta_a$$

$$Q_b = \frac{\omega}{kT} \int_{\tau}^{\tau+kT} i_b \left[ \int v_b dt \right] dt = V_b I_b \sin \theta_b$$

$$Q_c = \frac{\omega}{kT} \int_{\tau}^{\tau+kT} i_c \left[ \int v_c dt \right] dt = V_c I_c \sin \theta_c$$

For the imaginary component of the vector apparent power  $S_V$  (see 3.2.2.6), the total reactive power  $Q$  is as follows:

$$\| Q = Q_a + Q_b + Q_c$$

NOTE—The previous expression of  $Q$  cannot be used in conjunction with the arithmetic apparent power  $S_A$ , which is defined in 3.2.2.5.

### 3.2.2.3.1 Positive-, negative-, and zero-sequence reactive powers (var)

The three reactive powers are as follows:

The positive-sequence reactive power

$$Q^+ = 3V^+ I^+ \sin \theta^+$$

The negative-sequence reactive power

$$Q^- = 3V^- I^- \sin \theta^-$$

The zero-sequence reactive power

$$Q^0 = 3V_{\text{in}}^0 I^0 \sin \theta^0$$

The total reactive power is

$$Q = Q^+ + Q^- + Q^0$$

### 3.2.2.4 Phase apparent powers (VA)

$$S_a = V_a I_a ; \quad S_b = V_b I_b ; \quad S_c = V_c I_c$$

$$S_a^2 = P_a^2 + Q_a^2 ; \quad S_b^2 = P_b^2 + Q_b^2 ; \quad S_c^2 = P_c^2 + Q_c^2$$

### 3.2.2.5 Arithmetic apparent power (VA)

$$S_A = S_a + S_b + S_c$$

NOTE 1—The arithmetic apparent power cannot be resolved according to 3.1.1.4,

$$S_A \neq \sqrt{P^2 + Q^2}$$

where

$$P = P_a + P_b + P_c$$

and

$$Q = Q_a + Q_b + Q_c$$

NOTE 2—It is recommended to renounce the arithmetic apparent power definition and replace it with the effective apparent power; see 3.2.2.8.

### 3.2.2.6 Vector apparent power (VA)

$$S_V = \sqrt{P^2 + Q^2}$$

$$S_V = |P_a + P_b + P_c + j(Q_a + Q_b + Q_c)| = |P + jQ|$$

$$S_V = |P^+ + P^- + P^0 + j(Q^+ + Q^- + Q^0)|$$

NOTE—It is recommended to renounce the vector apparent power definition and replace it with the effective apparent power; see 3.2.2.8.

A geometrical interpretation of  $S_V$  and  $S_A$  is presented in Figure 3.

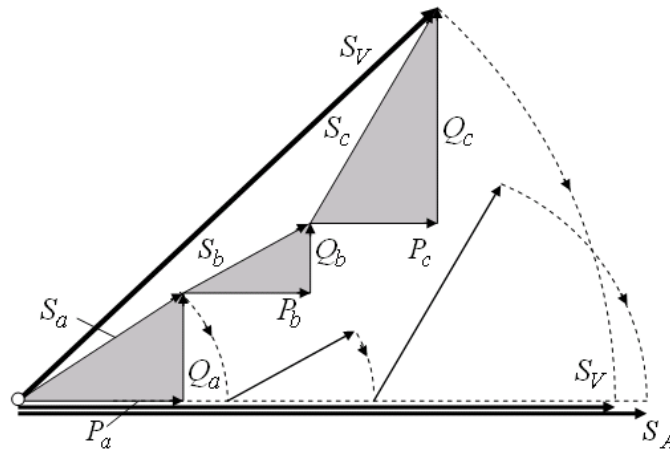

Figure 3—Arithmetic and vector apparent powers (VA)

#### 3.2.2.6.1 Positive-, negative-, and zero-sequence apparent powers (VA)

$$S^+ = |S^+| = |P^+ + jQ^+|$$

$$S^- = |S^-| = |P^- + jQ^-|$$

$$S^0 = |S^0| = |P^0 + jQ^0|$$

$$S_V = |S^+ + S^- + S^0|$$

$$S_A \neq S^+ + S^- + S^0$$

#### 3.2.2.7 Vector power factor and arithmetic power factor

$$\text{PF}_V = \frac{P}{S_V}$$

$$\text{PF}_A = \frac{P}{S_A}$$

NOTE—A three-phase line supplying one or more customers should be viewed as one single path, one entity that transmits the electric energy to locations where it is converted into other forms of energy. It is wrong to view each phase as an independent energy route. In poly-phase systems, the meaning of power factor as a utilization indicator is retained (see 3.1.2.16). Unity power factor means minimum possible line losses for a given total active power transmitted. The following example helps clarify certain limitations pertinent to the outdated, old apparent power definitions  $S_A$  and  $S_V$ .

EXAMPLE:

A four-wire, three-phase system, Figure 4(a), supplies a resistance  $R$  connected between phases a and b. The active power dissipated by  $R$  is as follows:

$$P_R = \frac{3V^2}{R}$$

and the line current  $I_a = \sqrt{3}V_{ln} / R$ . Assuming each line has the resistance  $r$ , the total power loss is

$$\Delta P = 6r \left( \frac{V}{R} \right)^2$$

Now, let us assume a second system with a perfectly balanced three-phase load, Figure 4(b), consisting of three resistances  $R_B$  connected in Y. This system dissipates the same active power as the unbalanced one; hence,

$$P_{RB} = 3 \frac{V^2}{R_B}$$

thus,  $R_B = R$  and the line currents flowing within the three lines, Figure 4(b), is

$$I = \frac{V}{R}$$

The line power loss for this balanced system is as follows:

$$\Delta P_B = 3r \left( \frac{V}{R} \right)^2 = 0.5 \Delta P$$



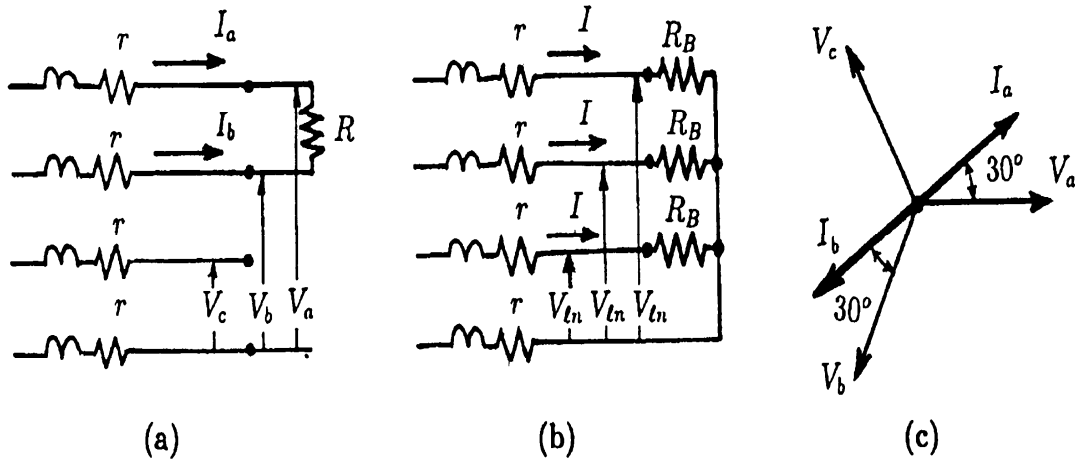

**Figure 4—Unbalanced system: (a) actual circuit, (b) balanced equivalent circuit, and (c) phasor diagram**

The power loss dissipated in the unbalanced system is twice the power loss in the balanced one. This observation leads to the conclusion that the unbalanced system has  $PF < 1$ . The balanced system operates with minimum possible losses for a given load voltage and active power; hence, its power factor is unity.

For the unbalanced system, the arithmetic and vector apparent powers have the following components [see phasor diagram in Figure 4(c)]:

$$P_a = V_a I_a \cos(30^\circ) = \frac{\sqrt{3}}{2} VI; \quad Q_a = V_a I_a \sin(30^\circ) = \frac{1}{2} VI; \quad S_a = V_a I_a = VI$$

$$P_b = V_b I_b \cos(-30^\circ) = \frac{\sqrt{3}}{2} VI; \quad Q_b = V_b I_b \sin(-30^\circ) = -\frac{1}{2} VI; \quad S_b = V_b I_b = VI$$

$$P_c = Q_c = S_c = 0$$

The total active power is

$$P = P_a + P_b = \sqrt{3} VI = \frac{3V^2}{R}$$

The total reactive power is

$$Q = Q_a + Q_b + Q_c = 0$$

The vector apparent power is

$$S_V = P$$

The arithmetic apparent power is

$$S_A = S_a + S_b + S_c = 2VI = 2\sqrt{3} \frac{V^2}{R}$$

The power factor computed for the unbalanced system using  $S_V$  gives  $PF_V = P / S_V = 1.0$ . The power factor computed with  $S_A$  gives  $PF_A = P / S_A = \sqrt{3} / 2 = 0.866$ .

If the unbalanced load consists of a resistance connected between line and neutral, then  $S_a = S_b = P$  and  $PF_A = PF_B = 1.0$ .

These results indicate that both the arithmetic and the vector apparent powers do not measure or compute power factor correctly for unbalanced loads. As a rule,  $PF_A \leq PF_B$ .

### 3.2.2.8 Effective apparent power (VA)

This concept assumes a virtual balanced circuit that has exactly the same line power losses as the actual unbalanced circuit. This equivalence leads to the definition of an effective line current  $I_e$  (see Depenbrock and Staudt [B4] and Emanuel [B8]).

For a four-wire system, the balance of power loss is expressed in the following way:

$$r(I_a^2 + I_b^2 + I_c^2 + \rho I_n^2) = 3rI_e^2$$

where

$r$  is the line resistance  
 $I_n$  is the neutral current (rms value)

$$\rho = \frac{r_n}{r}$$

$r_n$  is the neutral wire (or the equivalent neutral current return path) resistance

From the previous equations, the equivalent current for a four-wire system is obtained.

$$\|I_e\| = \sqrt{\frac{I_a^2 + I_b^2 + I_c^2 + \rho I_n^2}{3}} = \sqrt{(I^+)^2 + (I^-)^2 + (1+3\rho)(I^0)^2}$$

In case that the value of the ratio  $\rho$  is not known, it is recommended to use  $\rho = 1.0$ .

For a three-wire system,  $I^0 = 0$  and

$$\|I_e\| = \sqrt{\frac{I_a^2 + I_b^2 + I_c^2}{3}} = \sqrt{(I^+)^2 + (I^-)^2}$$

NOTE—In practical systems,  $\rho$  is time dependent. The complicated topology of the power network as well as the unknown neutral path resistance, that is function of soil moisture and temperature, make the correct estimation of  $\rho$  nearly impossible. Since the zero-sequence resistance of three-phase lines is larger than the positive sequence resistance, it can be concluded that  $\rho > 1.0$ , and taking  $\rho = 1.0$  will not put the customer at disadvantage when computing  $I_e$  (see Pajic and Emanuel [B16] and DIN 40110-1997).

The equivalent voltage is obtained assuming that the active components of the load consist of a set of three equivalent resistances  $R_Y$  connected in Y, supplied by a four-wire line and dissipating the active power  $P_Y$ . The remaining active load consists of three  $\Delta$ -connected equivalent resistances,  $R_\Delta$ , that dissipate the power  $P_\Delta$ . The power equivalence between the actual and the equivalent system is expressed as follows:

$$\frac{V_a^2 + V_b^2 + V_c^2}{R_Y} + \frac{V_{ab}^2 + V_{bc}^2 + V_{ca}^2}{R_\Delta} = 3 \frac{V_e^2}{R_Y} + \frac{9V_e^2}{R_\Delta}$$

where

$V_e$  is the effective line-to-neutral voltage.

With the notation

$$\xi = \frac{P_\Delta}{P_Y} = \frac{9V_e^2}{R_\Delta} \frac{R_Y}{3V_e^2} = \frac{3R_Y}{R_\Delta}$$

results

$$\|V_e\| = \sqrt{\frac{3(V_a^2 + V_b^2 + V_c^2) + \xi(V_{ab}^2 + V_{bc}^2 + V_{ca}^2)}{9(1 + \xi)}} = \sqrt{(V^+)^2 + (V^-)^2 + \frac{(V^0)^2}{1 + \xi}}$$

In case that the value of the ratio  $\xi$  is not known, it is recommended to use  $\xi = 1.0$ , thus leading to the following expression:

$$\|V_e\| = \sqrt{\frac{3(V_a^2 + V_b^2 + V_c^2) + V_{ab}^2 + V_{bc}^2 + V_{ca}^2}{18}} = \sqrt{(V^+)^2 + (V^-)^2 + \frac{(V^0)^2}{2}}$$

NOTE—In most practical systems,  $V^0 / V^+ < 0.04$  and the ratio  $\xi$  does not affect the value of  $V_e$ .

For practical situations where the differences between  $\alpha_a$ ,  $\alpha_b$ , and  $\alpha_c$  do not exceed  $\pm 10^\circ$  and the differences among the line-to-neutral voltages remain within the range of  $\pm 10\%$ , the following simplified expression can be used:

$$\|V_e\| = \sqrt{\frac{V_{ab}^2 + V_{bc}^2 + V_{ca}^2}{9}} = \sqrt{(V^+)^2 + (V^-)^2}$$

The error caused by this simplified expression is less than 0.2% for the above conditions. This equation gives accurate results for three-wire systems.

The effective apparent power (see Buchholtz [B1] and Goodhue [B7]) is as follows:

$$\|S_e = 3V_e I_e$$

NOTE 1—Applying the concept of  $S_e$  to the unbalanced circuit described in the example given in 3.2.2.7 results in the following:

$$V_e = V; \quad I_e = \sqrt{\frac{I_a^2 + I_b^2}{3}} = \frac{\sqrt{2}V}{R}$$

$$S_e = 3\sqrt{2} \frac{V^2}{R}; \quad P = \frac{3V^2}{R}$$

Hence the power factor is as follows:

$$\text{PF}_e = \frac{P}{S_e} = \frac{1}{\sqrt{2}} = 0.707 < \text{PF}_A < \text{PF}_V$$

NOTE 2—When the system is balanced, then

$$V_a = V_b = V_c = V = V_e$$

$$I_a = I_b = I_c = I$$

$$I_n = 0$$

and

$$S_V = S_A = S_e$$

NOTE 3—When the system is unbalanced, then

$$S_V \leq S_A \leq S_e$$

and

$$\text{PF}_e < \text{PF}_A < \text{PF}_V$$

NOTE 4—Both the vector and the arithmetic apparent powers do not satisfy the linearity requirement of system power loss versus the apparent power squared (see Emanuel [B8]).

### 3.2.2.9 Effective power factor

$$\| \text{PF}_e = P / S_e$$

### 3.2.2.10 Positive-sequence power factor

$$\text{PF}^+ = P^+ / S^+$$

This index has the same significance as the fundamental power factor  $PF_1$  (see 3.1.2.15). It helps evaluate the positive-sequence power flow conditions.

### 3.2.2.11 Unbalanced power (VA)

$$S_U = \sqrt{S_e^2 - (S^+)^2}$$

It evaluates the amount of VA caused by the system unbalance. It should not be confused with the voltage unbalance. It reflects on both the load unbalance and the voltage asymmetry.

where

$$S^+ = 3V^+I^+ \quad \text{is the positive-sequence apparent power}$$

$$(S^+)^2 = (P^+)^2 + (Q^+)^2$$

### 3.2.3 Three-phase nonsinusoidal and unbalanced systems

This subclause covers the most general case. It deals with all the situations presented in the 3.2.1 through 3.2.2.

#### 3.2.3.1 The effective apparent power and its resolution

In the past,  $S_e$  was divided into active power  $P$  and nonactive power  $N$  as follows:

$$S_e^2 = P^2 + N^2$$

This approach, however, does not separate out the positive-sequence fundamental powers. The approach used in 3.1.2.8 to 3.1.2.14 and 3.2.2.8 can be expanded for this situation.

For a four-wire system, the balance of losses in the actual line and the fictitious one is

$$3r_e I_e^2 = r_{dc} \sum_h K_{sh} (I_{ah}^2 + I_{bh}^2 + I_{ch}^2) + r_{ndc} \sum_h K_{snh} I_{nh}^2$$

The equivalent resistance  $r_e = K_{s1} r_{dc}$  (i.e., the line resistance measured at fundamental frequency), where  $r_{dc}$  is the dc resistance and  $K_{s1}$  is the skin and proximity effect coefficient at fundamental frequency (most common being 60 or 50 Hz). Thus, the equivalent current will have the following expression:

$$I_e = \sqrt{\frac{1}{3} \left\{ \sum_h \left[ \frac{K_{sh}}{K_{s1}} (I_{ah}^2 + I_{bh}^2 + I_{ch}^2) + \frac{K_{snh} r_{ndc}}{K_{s1} r_{dc}} I_{nh}^2 \right] \right\}}$$

where

$K_{sh}, K_{snh}$  are the skin and proximity effect coefficients of the supplying line conductor and the neutral current path, respectively, computed for the  $h$  harmonic order, or any frequency component present in the currents spectra  
 $r_{ndc}$  is the dc resistance of the neutral current path

The rms effective current can be separated into two components—the fundamental  $I_{e1}$  and the nonfundamental  $I_{eH}$ , (see Emanuel [B8] and IEEE Working Group [B14]).

$$I_e = \sqrt{I_{e1}^2 + I_{eH}^2}$$

$$I_{e1} = \sqrt{\frac{1}{3}[(I_{a1}^2 + I_{b1}^2 + I_{c1}^2) + \rho_1 I_{n1}^2]}; \quad \rho_1 = \frac{K_{sn1} r_{ndc}}{K_{s1} r_{dc}}$$

$$I_{eH} = \sqrt{\frac{1}{3} \left\{ \sum_{h \neq 1} \left[ \kappa_h (I_{ah}^2 + I_{bh}^2 + I_{ch}^2) + \rho_h I_{nh}^2 \right] \right\}}; \quad \kappa_h = \frac{K_{sh}}{K_{s1}} \quad \rho_h = \frac{K_{snh} r_{ndc}}{K_{s1} r_{dc}}$$

In most practical applications, the ratios  $\rho_1$ ,  $\rho_h$ , and  $\kappa_h$  are not known. Moreover, these ratios are function of temperature, network topology, and loading. Until tools that allow the correct determination of such values will be available, it is recommended to use the values  $\rho_1 = \rho_h = \kappa_h = 1.0$ . This approach leads to simpler expressions that do not disadvantage the user (i.e., yield for the effective current a value smaller than the value obtained from the exact expression). The practical expressions are as follows:

$$\| I_e = \sqrt{\frac{I_a^2 + I_b^2 + I_c^2 + I_n^2}{3}}$$

$$\| I_{e1} = \sqrt{\frac{I_{a1}^2 + I_{b1}^2 + I_{c1}^2 + I_{n1}^2}{3}}$$

$$I_{eH} = \sqrt{\frac{I_{aH}^2 + I_{bH}^2 + I_{cH}^2 + I_{nH}^2}{3}} = \sqrt{I_e^2 - I_{e1}^2} \quad \parallel$$

For three-wire systems,  $I_{n1} = I_{nh} = 0$  and the expressions become simpler.

$$\| I_e = \sqrt{\frac{I_a^2 + I_b^2 + I_c^2}{3}}$$

$$\| I_{e1} = \sqrt{\frac{I_{a1}^2 + I_{b1}^2 + I_{c1}^2}{3}}$$

$$I_{eH} = \sqrt{\frac{I_{aH}^2 + I_{bH}^2 + I_{cH}^2}{3}} = \sqrt{I_e^2 - I_{e1}^2} \quad \parallel$$

The practical expressions for the effective voltage are obtained in a similar manner

$$V_e = \sqrt{V_{e1}^2 + V_{eH}^2}$$

$$\|V_e\| = \sqrt{\frac{1}{18} \left[ 3(V_a^2 + V_b^2 + V_c^2) + V_{ab}^2 + V_{bc}^2 + V_{ca}^2 \right]}$$

$$\|V_{e1}\| = \sqrt{\frac{1}{18} \left[ 3(V_{a1}^2 + V_{b1}^2 + V_{c1}^2) + V_{ab1}^2 + V_{bc1}^2 + V_{ca1}^2 \right]}$$

$$V_{eH} = \sqrt{\frac{1}{18} \left[ 3(V_{aH}^2 + V_{bH}^2 + V_{cH}^2) + V_{abH}^2 + V_{bcH}^2 + V_{caH}^2 \right]} = \sqrt{V_e^2 - V_{e1}^2} \quad \parallel$$

For three-wire systems

$$\|V_e\| = \sqrt{\frac{V_{ab}^2 + V_{bc}^2 + V_{ca}^2}{9}}$$

$$\|V_{e1}\| = \sqrt{\frac{V_{ab1}^2 + V_{bc1}^2 + V_{ca1}^2}{9}}$$

$$V_{eH} = \sqrt{\frac{V_{abH}^2 + V_{bcH}^2 + V_{caH}^2}{9}} = \sqrt{V_e^2 - V_{e1}^2} \quad \parallel$$

The resolution of  $S_e = 3V_e I_e$  is implemented in the manner shown in 3.1.2.9 to 3.1.2.14.

$$S_e^2 = S_{e1}^2 + S_{eN}^2$$

where

$$\|S_{e1}\| = 3V_{e1} I_{e1}$$

is the fundamental effective apparent power and  $S_{eN}$  is the nonfundamental effective apparent power. The resolution of  $S_{eN}$  is identical to the resolution of  $S_N$  given in 3.1.2.9.

$$\|S_{eN}^2\| = S_e^2 - S_{e1}^2 = D_{e1}^2 + D_{eV}^2 + S_{eH}^2$$

The current distortion power, voltage distortion power, and harmonic apparent power are as follows:

$$\|D_{e1}\| = 3V_{e1} I_{eH}$$

$$\|D_{eV}\| = 3V_{eH} I_{e1}$$

$$\|S_{eH}\| = 3V_{eH} I_{eH}$$

and

$$\| D_{eH} = \sqrt{S_{eH}^2 - P_{eH}^2}$$

By defining the equivalent total harmonic distortions as follows:

$$\| \text{THD}_{eV} = \frac{V_{eH}}{V_{e1}}$$

$$\| \text{THD}_{eI} = \frac{I_{eH}}{I_{e1}}$$

practical expressions, identical to those found in 3.1.2.10 through 3.1.2.14, for the nonfundamental apparent power  $S_{eN}$  and its components  $D_{eI}$ ,  $D_{eV}$ , and  $S_{eH}$  are obtained.

$$S_{eN} = \sqrt{\text{THD}_{eI}^2 + \text{THD}_{eV}^2 + (\text{THD}_{eI} \text{THD}_{eV})^2}$$

$$\| D_{eI} = S_{eI} (\text{THD}_{eI})$$

$$\| D_{eV} = S_{eI} (\text{THD}_{eV})$$

$$\| S_{eH} = S_{eI} (\text{THD}_{eV}) (\text{THD}_{eI})$$

For systems with  $\text{THD}_{eV} \leq 5\%$  and  $\text{THD}_{eI} \geq 40\%$ , the following approximation is recommended (see IEEE Working Group [B14]):

$$\| S_{eN} = S_{eI} (\text{THD}_{eI})$$

The load unbalance can be evaluated using the following fundamental unbalanced power:

$$\| S_{U1} = \sqrt{S_{e1}^2 - (S_1^+)^2}$$

where

$S_1^+$  is the fundamental positive-sequence apparent power (VA). This important apparent power contains the following components:

$P_1^+ = 3V_1^+ I_1^+ \cos\theta_1^+$  is the fundamental active power (W).

$Q_1^+ = 3V_1^+ I_1^+ \sin\theta_1^+$  is the fundamental reactive power (var).

Together they result in

$$S_1^+ = \sqrt{(P_1^+)^2 + (Q_1^+)^2}$$



and the fundamental positive-sequence power factor

$$\| \text{PF}_1^+ = \frac{P_1^+}{S_1^+}$$

that plays the same significant role that the fundamental power factor has in nonsinusoidal single-phase systems.

The power factor is

$$\| \text{PF} = \frac{P}{S_e}$$

The most important definitions are summarized in Table 2.

**Table 2—Summary and grouping of quantities for three-phase systems with nonsinusoidal waveforms**

Quantity or indicator	Combined	Fundamental powers	Nonfundamental powers
Apparent	$S_e$ (VA)	$S_{e1}$ $S_1^+$ $S_{1U}$ (VA)	$S_{eN}$ (VA) $S_{eH}$
Active	$P$ (W)	$P_1^+$ (W)	$P_H$ (W)
Non-active	$N$ (var)	$Q_1^+$ (var)	$D_{e1}$ $D_{eV}$ (var) $D_{eH}$
Line utilization	$\text{PF} = P / S_e$	$\text{PF}_1^+ = P_1^+ / S_1^+$	—
Harmonic pollution	—	—	$S_{eN} / S_{e1}$
Load unbalance	—	$S_{1U} / S_1^+$	—

Table 2 lists the three basic powers: apparent, active, and nonactive. The columns are partitioned into three groups—the combined powers, the fundamental powers, and the nonfundamental powers. The last three rows give the following indices: power factors (i.e., line utilization factor), harmonic pollution factor, and load unbalance factor.

## Annex A

(informative)

### Theoretical examples

#### A.1 The effect of the integration interval

Table A.1 summarizes voltage and current phasor values at the input terminals of a nonlinear load taking a total active power  $P = 4072.716$  W. The oscillograms are presented in Figure A.1.

**Table A.1—Phasors and the active powers of the studied load**

<b>h</b>	<b>f (Hz)</b>	$V_h/\alpha_h$ <b>(V)</b>	$I_h/\beta_h$ <b>(A)</b>	$P_h = V_h I_h \cos(\beta_h - \alpha_h)$ <b>(W)</b>
0.0217	1.302	$3.5 \cdot 10^{-4} / \underline{-90.0}$	$1.48 / \underline{80.2}$	$-5.1734 \cdot 10^{-4}$
0.0433	2.598	$1.4 \cdot 10^{-3} / \underline{-107.3}$	$2.26 / \underline{-8.4}$	$-4.9507 \cdot 10^{-4}$
0.957	57.42	$0.16 / \underline{-75.5}$	$0.92 / \underline{-173.5}$	-0.0208
0.978	58.68	$0.56 / \underline{-97.2}$	$2.24 / \underline{-193.2}$	-0.1329
1.0	60	$70.71 / \underline{-7.2}$	$70.71 / \underline{-42.4}$	4085.72
1.022	61.32	$0.46 / \underline{-82.9}$	$1.75 / \underline{-178.9}$	-0.08425
1.043	62.58	$0.35 / \underline{-104.3}$	$0.91 / \underline{-202.3}$	-0.04488
3.0	180	$5.02 / \underline{-76.0}$	$19.09 / \underline{18.3}$	-7.18671
4.268	256.1	$0.95 / \underline{176.4}$	$5.43 / \underline{-87.0}$	-0.59219
5.0	300	$3.18 / \underline{-114.0}$	$7.64 / \underline{-15.8}$	-3.46588
7.0	420	$2.33 / \underline{-142.0}$	$3.68 / \underline{-43.2}$	-1.31261
9.0	540	$1.13 / \underline{-165.0}$	$1.41 / \underline{-69.0}$	-0.16724

The voltage and current waves contain harmonics (fundamental, 3rd, 5th, 7th, and 9th) as well as three interharmonics ( $h = 1.022, 1.043,$  and  $4.268$ ) and four subsynchronous interharmonics ( $h = 0.0217, 0.0433, 0.957,$  and  $0.978$ ).

Figure A.2 graphs the theoretical error

$$\% \varepsilon_P = \left[ \frac{\frac{1}{t} \int_0^t v i dt}{4072.716} - 1 \right] 100$$

versus time for  $200 \text{ ms} < t < 3000 \text{ ms}$ . At  $t = 200 \text{ ms}$ , the error is approximately  $-4\%$ , and as the measurement time reaches  $3000 \text{ ms} = 180$  cycles, the error is significantly reduced.

Figure A.3 presents the error obtained when only the power of the interharmonic of order  $h = 4.268$  is measured. In this case, the error can be significant, reaching approximately 112% at  $t = 300$  ms and converging toward  $\pm 8\%$  around  $t = 3000$  ms.

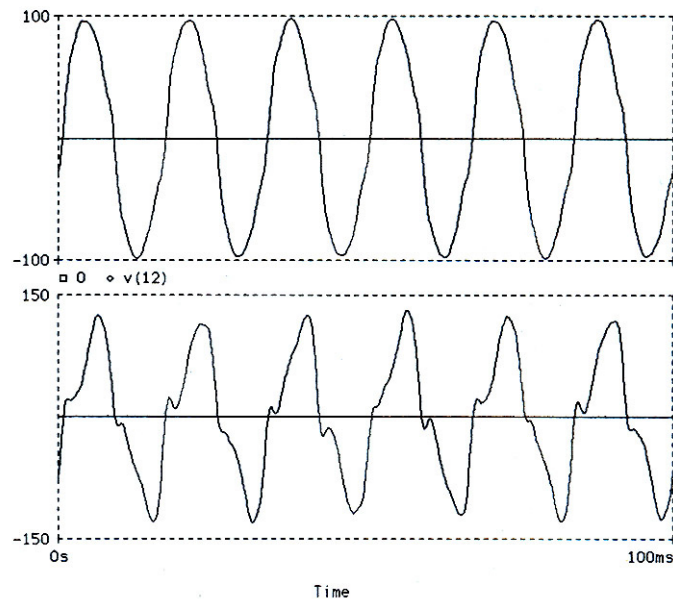

**Figure A.1— Studied voltage (upper trace) and current (lower trace) oscillograms**

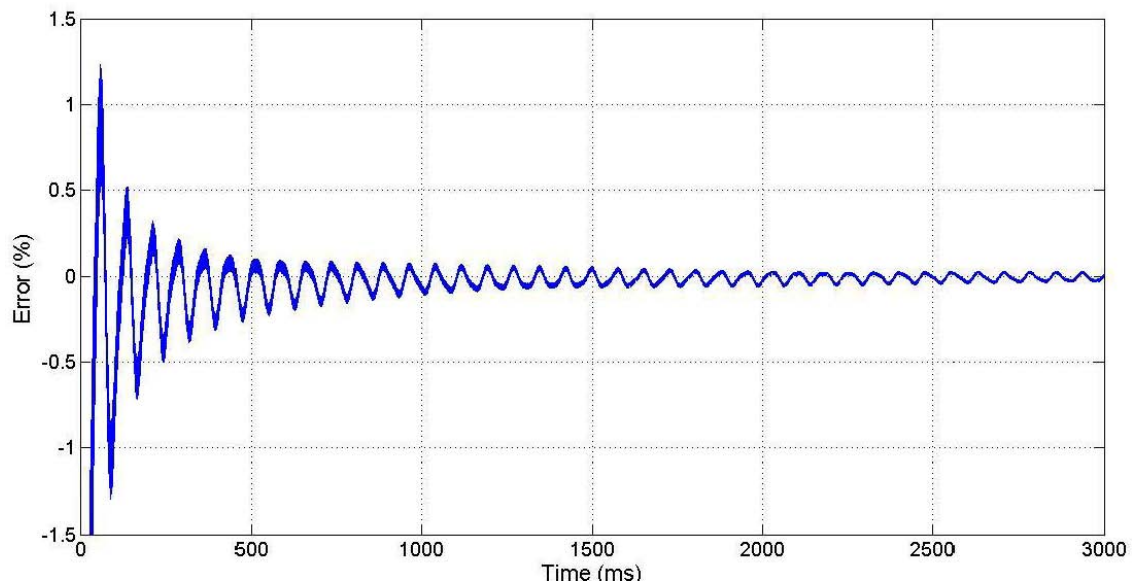

**Figure A.2—Total active power measurement percent error versus measurement time**

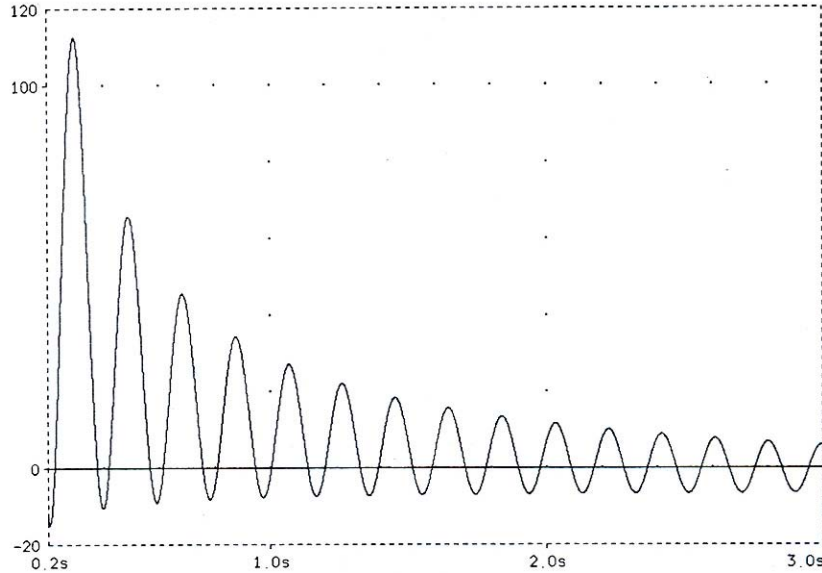

**Figure A.3—Interharmonic of order  $h = 4.268$ : active power measurement percent error versus measurement time**

## A.2 The use of varmeters in the presence of distorted waveforms

Varmeters that use  $90^\circ$  phase shift in time of fundamental may measure correctly the reactive power under sinusoidal conditions. When the voltage and current waveforms are highly distorted, such meters yield a reading that has questionable significance (see Filipski, and Labaj [B9]; Filipski et al. [B10]; Cataliotti et al. [B2], and *The IEEE Standards Dictionary: Glossary of Terms & Definitions*<sup>6</sup>). The theoretical expressions of the measured results depend on the definition on which the meter design is based

Case A:

$$Q = \frac{1}{kT} \int_{\tau}^{\tau+kT} v(t)i(t-T/4)dt = Q_1 + P_0 - P_2 + Q_3 - P_4 + Q_5 \dots$$

where

$$Q_1 = V_1 I_1 \sin(\theta_1) ; P_0 = V_0 I_0 ; P_2 = V_2 I_2 \cos(\theta_2) ; Q_3 = V_3 I_3 \sin(\theta_3)$$

Case B:

$$Q = \frac{\omega}{kT} \int_{\tau}^{\tau+kT} \left[ \int v dt \right] i(t) dt = Q_1 + k\pi P_0 + \frac{Q_2}{2} + \frac{Q_3}{3} + \dots + \frac{Q_h}{h}$$

<sup>6</sup> *The IEEE Standards Dictionary: Glossary of Terms & Definitions* is available at <http://shop.ieee.org/>.

Case C:

$$Q = \frac{-1}{kT\omega} \int_{\tau}^{\tau+kT} i \frac{dv}{dt} dt = Q_1 + 2Q_2 + 3Q_3 + \dots + hQ_h$$

Varmeters that operate according to Budeanu's definition (see Czarnecki [B3] and Lyon [B15]) will measure

$$Q_B = Q_1 + Q_2 + Q_3 + \dots + Q_h$$

Because  $Q_h = V_h I_h \sin(\theta_h)$  can be positive or negative, it results that  $Q \leq \sum_{h=1} |Q_h|$ ; hence,  $Q_B^2$  is not a reliable indicator of the thermal stress caused in the conductors by the reactive power (see Pretorius et al. [B18]).

In conclusion, when the voltage or the current waveforms are highly distorted, none of the previous methods yield a correct value for the fundamental reactive power or for the nonactive powers defined in this standard (see 3.1.1.3 and 3.1.2.9).

This standard emphasizes  $Q_1$ , the fundamental reactive power, and  $Q_1^+$ , the fundamental positive-sequence reactive power, as separate quantities.

The effective apparent power is separated in five basic components (see 3.2.3.1 and Annex B):

$$S_e^2 = P_1^2 + Q_1^2 + D_{eI}^2 + D_{eV}^2 + S_{eH}^2$$

The terms  $D_{eI}$ ,  $D_{eV}$  and a large part of  $S_{eH}$  are nonactive powers that correctly correlate with the line power losses caused by instantaneous power components that oscillate between the measured load and the voltage source.

These components (except the harmonic active power  $P_{eH} = \sqrt{S_{eH}^2 - D_{eH}^2}$ ) do not transfer net energy to the load.

## Annex B

(informative)

### Practical studies and measurements: A detailed explanation of apparent power components

A load is supplied with a nonsinusoidal voltage

$$v = v_1 + v_2 + v_5 + v_7 = \sqrt{2} \sum_{h=1,3,5,7} V_h \sin(h\omega t - \alpha_h)$$

has a nonsinusoidal current

$$i = i_1 + i_2 + i_5 + i_7 = \sqrt{2} \sum_{h=1,3,5,7} I_h \sin(h\omega t - \beta_h)$$

(To simplify the explanations, the eventual presence of dc components was ignored.)

In this case, the instantaneous power has 16 terms that can be separated in two groups

$$p = vi = p_{hh} + p_{mn}$$

where

$$p_{hh} = v_1 i_1 + v_3 i_3 + v_5 i_5 + v_7 i_7 = \sum_{h=1,3,5,7} v_h i_h$$

is the instantaneous power that contains only direct products (i.e., each component is the result of interaction of voltage and current harmonics of the same order).

$$p_{mn} = v_1(i_3 + i_5 + i_7) + v_3(i_1 + i_5 + i_7) + v_5(i_1 + i_3 + i_7) + v_7(i_1 + i_3 + i_7) = \sum_{m=1,3,5,7} v_m \sum_{\substack{n=1,3,5,7 \\ n \neq m}} i_n$$

is the instantaneous power that contains only cross products (i.e., each component is the result of interaction of voltage and current harmonics of different orders).

The direct products yield

$$v_h i_h = \sqrt{2} V_h \sin(h\omega t - \alpha_h) \sqrt{2} I_h \sin(h\omega t - \beta_h) = P_h [1 - \cos(2h\omega t - 2\alpha_h)] - Q_h \sin(2h\omega t - 2\alpha_h)$$

where

$$P_h = V_h I_h \cos(\theta_h) \text{ and } Q_h = V_h I_h \sin(\theta_h)$$

are the harmonic active and reactive powers of order  $h$ , respectively, and  $\theta_h = \beta_h - \alpha_h$  is the phase angle between the phasors  $V_h$  and  $I_h$ .

The total active power is

$$P = \sum_{h=1,3,5,7} P_h = P_1 + P_H$$

where

$$P_1 = V_1 I_1 \cos(\theta_1) \quad \text{is the fundamental (power-frequency) active power}$$

$$P_H = P_3 + P_5 + P_7 = \sum_{h \neq 1} P_h \quad \text{is the total harmonic active power}$$

For each harmonic order, there is an apparent power of order  $h$

$$S_h = \sqrt{P_h^2 + Q_h^2}$$

The cross-products of the instantaneous powers have expressions as follows:

$$v_m i_n = \sqrt{2} V_m \sin(m\omega t - \alpha_m) \sqrt{2} I_n \sin(n\omega t - \beta_n) = D_{mn} \{ \cos[(m-n)\omega t - \alpha_m + \beta_n] + \cos[(m+n)\omega t - \alpha_m - \beta_n] \}$$

where

$$D_{mn} = V_m I_n$$

The total apparent power squared

$$S^2 = V^2 I^2 = (V_1^2 + V_3^2 + V_5^2 + V_7^2)(I_1^2 + I_3^2 + I_5^2 + I_7^2)$$

may be separated in the same manner as the instantaneous power, in direct and the cross-products:

$$S^2 = V_1^2 I_1^2 + V_3^2 I_3^2 + V_5^2 I_5^2 + V_7^2 I_7^2 + V_1^2 (I_3^2 + I_5^2 + I_7^2) + I_1^2 (V_3^2 + V_5^2 + V_7^2) \\ + V_3^2 I_5^2 + V_3^2 I_7^2 + V_5^2 I_3^2 + V_5^2 I_7^2 + V_7^2 I_3^2 + V_7^2 I_5^2$$

or

$$S^2 = S_1^2 + S_3^2 + S_5^2 + S_7^2 + D_I^2 + D_V^2 + D_{35}^2 + D_{37}^2 + D_{53}^2 + D_{57}^2 + D_{73}^2 + D_{75}^2 = S_1^2 + S_N^2$$

where

$$S_1^2 = P_1^2 + Q_1^2$$

with  $S_1$ ,  $P_1$ , and  $Q_1$  are the apparent, active, and reactive fundamental powers, and

$$S_N^2 = D_I^2 + D_V^2 + S_H^2$$

where

$$D_I^2 = V_1^2 (I_3^2 + I_5^2 + I_7^2) \quad \text{is the current distortion power}$$

$$D_V^2 = I_1^2 (V_3^2 + V_5^2 + V_7^2) \quad \text{is the voltage distortion power}$$

$$\begin{aligned} S_H^2 &= S_3^2 + S_5^2 + S_7^2 + D_{35}^2 + D_{37}^2 + D_{53}^2 + D_{57}^2 + D_{73}^2 + D_{75}^2 \\ &= P_3^2 + P_5^2 + P_7^2 + Q_3^2 + Q_5^2 + Q_7^2 + D_{35}^2 + D_{37}^2 + D_{53}^2 + D_{57}^2 + D_{73}^2 + D_{75}^2 \end{aligned} \quad (\text{B1})$$

is the harmonic apparent power

If the load is supplied by a line with a resistance  $r$  the power loss in the line is

$$\Delta P = rI^2 = \frac{r}{V^2} S^2 = \frac{r}{V^2} (S_1^2 + S_N^2) = \frac{r}{V^2} (P_1^2 + Q_1^2 + D_I^2 + D_V^2 + S_H^2) \quad (\text{B2})$$

It is learned from this expression that every component of  $S$  contributes to the total power loss in the supplying system. This means that not only fundamental active and reactive powers cause losses but also the current and voltage distortion powers as well as the harmonic apparent power cause losses.

The following numerical example is meant to facilitate the understanding of the previous explanations:

The instantaneous voltages and currents are

$$\begin{aligned} v_1 &= \sqrt{2} 100 \sin(\omega t - 0^\circ) & i_1 &= \sqrt{2} 100 \sin(\omega t - 30^\circ) \\ v_3 &= \sqrt{2} 8 \sin(3\omega t - 70^\circ) & i_3 &= \sqrt{2} 20 \sin(3\omega t - 165^\circ) \\ v_5 &= \sqrt{2} 15 \sin(5\omega t + 140^\circ) & i_5 &= \sqrt{2} 15 \sin(5\omega t + 234^\circ) \\ v_7 &= \sqrt{2} 5 \sin(7\omega t + 20^\circ) & i_7 &= \sqrt{2} 10 \sin(7\omega t + 234^\circ) \end{aligned}$$

The calculated active powers are summarized in Table B.1.

**Table B.1—Active powers**

$P_1$ (W)	$P_3$ (W)	$P_5$ (W)	$P_7$ (W)	$P$ (W)	$P_H$ (W)
8660.00	-13.94	-11.78	-1.74	8632.54	-27.46

The total harmonic active power  $P_H = -27.46 \text{ W} < 0$  is supplied by the load and injected into the power system. This condition is typical for dominant nonlinear loads. The bulk of the active power is supplied to the load by the fundamental component  $P_1 = 8660.0 \text{ W}$ .

The four reactive powers are given in Table B.2.



**Table B.2—Reactive powers**

$Q_1$ (var)	$Q_3$ (var)	$Q_5$ (var)	$Q_7$ (var)
5000.00	159.39	-224.69	49.97

Of interest is the fact that  $Q_5 < 0$ , whereas other reactive powers are positive. If one incorrectly defines a total reactive power as the sum of the four reactive powers (in accordance with C. Budeanu's definition):

$$Q_B = Q_1 + Q_3 + Q_5 + Q_7 = 4984.67 \text{ var}$$

and assumes that the supplying line has a resistance  $r = 1.0 \Omega$  and the load is supplied with an rms voltage  $V = 240 \text{ V}$ , the power loss due to  $Q_B$  in line is

$$\Delta P_B = \frac{r}{V^2} Q_B^2 = \frac{1}{240^2} 4984.67^2 = 431.37 \text{ W}$$

According to the previous analysis, [see Equation (B1) and Equation (B2)], the correct way to find the corresponding power loss due to  $Q_1$ ,  $Q_3$ ,  $Q_5$ , and  $Q_7$  is

$$\Delta P = \frac{r}{V^2} (Q_1^2 + Q_3^2 + Q_5^2 + Q_7^2) = 435.39 \text{ W} > \Delta P_B$$

The reactive power  $Q_5$ , despite its negative value, contributes to the line losses in the same way as the positive reactive powers. The fact that harmonic reactive powers of different orders oscillate with different frequencies reinforces the conclusion that the reactive powers should not be added arithmetically (as recommended by Budeanu).

The cross-products that produce the distortion powers  $D_I$  and  $D_V$  are given in Table B.3.

**Table B.3—Distortion powers and their components**

$D_{13}$ (var)	$D_{15}$ (var)	$D_{17}$ (var)	$D_I$ (var)
2000.00	1500.00	1000.00	2692.58
$D_{31}$ (var)	$D_{51}$ (var)	$D_{71}$ (var)	$D_V$ (var)
800.00	1500.00	500.00	1772.00

Finally the remaining cross-products that belong to the harmonic apparent power are presented in Table B.4.

**Table B.4—Distortion harmonic powers**

$D_{35}$ (var)	$D_{37}$ (var)	$D_{53}$ (var)	$D_{57}$ (var)	$D_{73}$ (var)	$D_{75}$ (var)
120.00	80.00	300.00	150.00	100.00	75.00

The studied system has the rms voltage and current:

$$V = 101.56 \text{ V and } I = 103.56 \text{ A with the total harmonic distortions}$$

$$\text{THD}_V = 0.177 \text{ and } \text{THD}_I = 0.269$$

The apparent power and its components are represented in the following tree:

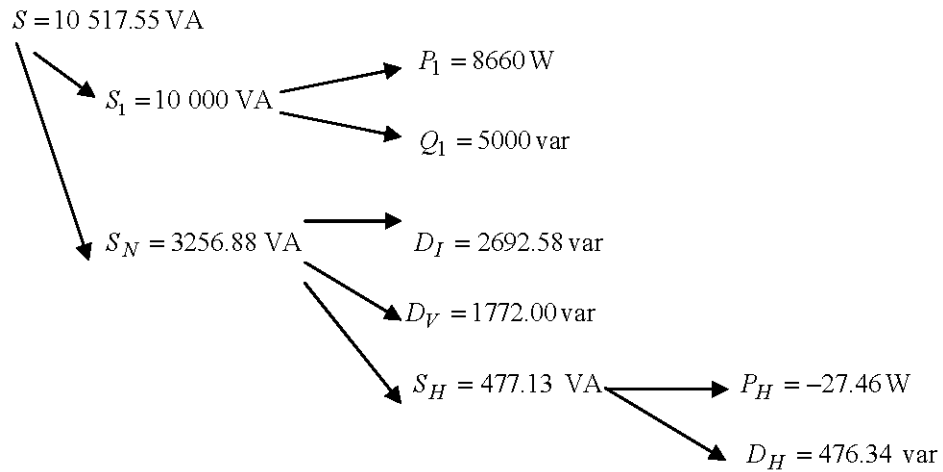

The fundamental power factor (displacement power factor) is  $PF_1 = P_1 / S_1 = 0.866$ , and the power factor is  $PF = P / S = 0.821$ . The dominant power components are  $P_1$  and  $Q_1$ . Due to relatively large distortion,  $S_N$  is found to be a significant portion of  $S$ , and the current distortion power  $D_I$  is the dominant component of  $S_N$ .

## Annex C

(informative)

### Bibliography

- [B1] Buchholz, F., “Die drehstrom-scheinleistung bei ungleichmassiger belastung der drei zweige,” *Licht und Kraft*, no. 2, pp. 9–11, Jan. 1922.
- [B2] Cataliotti, A., Cosentino, V., and Nuccio, S., “The measurement of reactive energy in polluted distribution power systems: an analysis of the performance of commercial static meters,” *IEEE Transactions on Power Delivery*, vol. 23, no. 3, pp. 1296–1301, July 2008.
- [B3] Czarnecki, L. S., “What is wrong with Budeanu’s concept of reactive and distortion power and why it should be abandoned,” *IEEE Transactions on Instrumentation and Measurement*, vol. IM-36, no. 3, Sept. 1987.
- [B4] Depenbrock, M., and Staudt, V., Discussion to “Practical definitions for powers in systems with non-sinusoidal waveforms and unbalanced loads,” *IEEE Transactions on Power Delivery*, vol. 11, no. 1, pp. 89–90, Jan. 1996.
- [B5] DIN 40110-1:1994, Quantities Used in Alternating Current Theory: Two-Line Circuits.<sup>7</sup>
- [B6] DIN 40110-2:2002, Quantities Used in Alternating Current Theory—Part 2: Multi-Line Circuits.
- [B7] Emanuel, A. E., “Apparent power definitions for three-phase systems,” *IEEE Transactions on Power Delivery*, vol. 14, no. 3, pp. 767–772, July 1999.
- [B8] Emanuel, A. E., “On the assessment of harmonic pollution,” *IEEE Transactions on Power Delivery*, vol. 10, no. 3, pp. 1693–1698, July 1995.
- [B9] Filipski, P. S., and Labaj, P. W., “Evaluation of reactive power meters in the presence of high harmonic distortion,” *IEEE Transactions on Power Delivery*, vol. 7, no. 4, pp. 1793–1799, Oct. 1992.
- [B10] Filipski, P. S., Baghzouz, Y., and Cox, M. D., “Discussion of Power Definitions Contained in the IEEE Dictionary,” *IEEE Transactions on Power Delivery*, vol. 9, no. 3, July 1994, pp. 1237–44.
- [B11] Goodhue, W. M., Discussion to “Reactive power concepts in need of clarification,” *AIEE Transactions*, vol. 52, p. 787, Sept. 1933.
- [B12] IEC 61000-4-7, 2002. Electromagnetic Compatibility (EMC)—Part 4-7: Testing and Measurement Techniques—General Guide on Harmonics and Interharmonics Measurements and Instrumentation, for Power Supply Systems and Equipment Connected Thereto.<sup>8</sup>
- [B13] IEEE Std 280™-1985 (Withdrawn), IEEE Standard Letter Symbols for Quantities Used in Electrical Science and Electrical Engineering.<sup>9,10,11</sup>
- [B14] IEEE Working Group on Non-Sinusoidal Situations, “Practical definitions for powers in systems with non-sinusoidal waveforms and unbalanced loads,” *IEEE Transactions on Power Delivery*, vol. 11, no. 1, pp. 79–101, Jan. 1996.

<sup>7</sup> DIN publications are available from DIN Deutsches Institut für Normung, e.V., Burggrafenstrabe 6, 10787 Berlin, Germany (<http://www.din.de>).

<sup>8</sup> IEC publications are available from the Sales Department of the International Electrotechnical Commission, Case Postale 131, 3 rue de Varembe, CH-1211, Genève 20, Switzerland/Suisse (<http://www.iec.ch/>). IEC publications are also available in the United States from the Sales Department, American National Standards Institute, 11 West 42nd Street, 13th Floor, New York, NY 10036, USA.

<sup>9</sup> IEEE publications are available from the Institute of Electrical and Electronics Engineers, 445 Hoes Lane, Piscataway, NJ 08854, USA (<http://standards.ieee.org/>).

<sup>10</sup> The IEEE standards or products referred to in this clause are trademarks owned by the Institute of Electrical and Electronics Engineers, Incorporated.

<sup>11</sup> IEEE Std 280-1985 has been withdrawn; however, copies can be obtained from Global Engineering, 15 Inverness Way East, Englewood, CO 80112-5704, USA, tel. (303) 792-2181 (<http://global.ihs.com/>).

- [B15] Lyon, V., [Discussion to H. L. Curtis and F. B. Silsbee paper “Definitions of power and related quantities,” *AIEE Transactions*, vol. 54, no. 4, pp. 394–404, Apr. 1935], *Electrical Engineering*, p. 1121, Oct. 1935.
- [B16] Pajic, S., and Emanuel, A. E., “Effect of neutral path power losses on the apparent power definition: A preliminary study,” *IEEE Transactions on Power Delivery*, vol. 24, no. 2, pp. 517–523, Apr. 2009.
- [B17] Peretto, L., Willems, J. L., and Emanuel, A. E., “The effect of the integration interval on the measurement accuracy of rms values and powers in systems with non-sinusoidal waveforms,” *Electrical Power Quality and Utilization Journal*, vol. 13, no.1, pp. 111–117, 2007.
- [B18] Pretorius, J. H. C., van Wyk, J. D., and Swart, P. H., “An evaluation of some alternative methods of power resolutions in a large industrial plant,” *IEEE Transactions on Power Delivery*, vol. 15, no. 3, pp. 1052–1059, July 2000.
- [B19] Stevens, R. H., “Power flow direction definitions for metering of bidirectional power,” *IEEE Transactions on Power Apparatus and Systems*, vol. 102, no. 9, pp. 3018–3021, Sept. 1983.
- [B20] Swart, P. H., van Wyk, J. D., and Case, M. J., “On the technique for localization of sources producing distortion in transmission networks,” *European Transactions on Electrical Powers (ETEP)*, vol. 6, no. 5, Sept./Oct. 1996.